



The Synchronization Experts.



## TECHNICAL REFERENCE

### LANTIME

### M900/GPS/FDM-D/BGT

March 1, 2022

Meinberg Funkuhren GmbH & Co. KG



# Table of Contents

<b>1</b>	<b>Imprint</b>	<b>1</b>
<b>2</b>	<b>Important Safety Information</b>	<b>2</b>
2.1	Important Safety Information and Safety Precautions	2
2.2	Used Symbols	3
2.3	Product Documentation	4
2.4	Safety during Installation	5
2.5	Connection of Protective Earth Conductor/Grounding	8
2.6	Safety during Operation	9
2.7	Safety during Maintenance	10
2.8	Handling of Batteries	11
2.9	Cleaning and Care	12
2.10	Prevention of ESD Damage	12
2.11	Return of Electrical and Electronic Equipment	13
<b>3</b>	<b>General Information about LANTIME</b>	<b>14</b>
<b>4</b>	<b>Frequency Deviation Module - FDM</b>	<b>15</b>
4.1	Overview	15
4.2	Functional Principle	15
4.3	Display String	16
4.4	FDM Technical Specifications	17
<b>5</b>	<b>Technical specifications 3U Chassis</b>	<b>18</b>
<b>6</b>	<b>LANTIME M900 Front Connectors</b>	<b>20</b>
6.1	GPS Receiver	23
6.2	Frequency Deviation Monitor (FDM)	24
6.2.1	FDM Push Buttons	25
6.2.2	FDM Status LEDs	25
6.2.3	FDM Display	26
<b>7</b>	<b>LANTIME M900 Rear Connectors</b>	<b>27</b>
7.1	Power Connector	28
7.2	Pulses Output	29
7.3	RS-232 COMx Timestring	29
7.4	Error Relay	30
7.5	10 MHz Frequency Output	31
7.6	Pulse per Second Output	31
7.7	Antenna Input: GPS Reference Clock	32
7.8	FDM COM0: RS-232	33
7.9	FDM COM 1: RS-232/RS-422	34
7.10	FDM Error Relay	35
7.11	FDM Analog Outputs	36
7.12	FDM Power Line	36
<b>8</b>	<b>Configuration and Status of the FDM</b>	<b>37</b>
8.1	Menu Entry: Frequency	37
8.2	Menu Entry: Frequency Deviation	37
8.3	Menu Entry: REF Time	37
8.4	Menu Entry: PL Time	38
8.5	Menu Entry: Time Deviation	38
8.6	Setup Submenu	39
8.6.1	Menu Entry: Nominal Frequency	39

8.6.2	Menu Entry: Time Deviation Init . . . . .	40
8.6.3	Menu Entry: COM Parameters (Par.COM0 and Par.COM1) . . . . .	40
8.6.4	Menu Entry: COMx Mode (Mod.COM0 and Mod.COM1) . . . . .	41
8.6.5	Menu Entry: Output String (Str.COM0 and Str.COM1) . . . . .	41
8.6.6	Menu Entry: Freq. Deviation Limit . . . . .	42
8.6.7	Menu Entry: Time Deviation Limit . . . . .	43
8.6.8	Menu Entry: Analog Outputs (Analog 1 and Analog 2) . . . . .	44
8.6.9	Menu Entry: Error . . . . .	45
8.6.10	Menu Entry: Serial Number . . . . .	46
8.6.11	Menu Entry: Firmware Revision . . . . .	46
8.7	Serial Output Strings . . . . .	47
8.7.1	Standard FDM String . . . . .	47
8.7.2	Short FDM String . . . . .	48
8.7.3	Time Deviation Preset String . . . . .	48
8.7.4	TTM1 FDM String . . . . .	49
8.7.5	Over Range Condition . . . . .	50
8.7.6	Time Deviation Preset . . . . .	50
8.7.7	TTM2 FDM String . . . . .	51
8.7.8	CompuTime Extended FDM String . . . . .	51
<b>9</b>	<b>Installation of the GPS Antenna</b>	<b>52</b>
<b>10</b>	<b>Technical Appendix: GPS Antenna + Accessories</b>	<b>56</b>
10.1	Antenna Cable . . . . .	58
10.2	Antenna Short Circuit . . . . .	58
10.3	Technical Specifications: MBG S-PRO Surge Protection . . . . .	59
10.3.1	MBG S-PRO: Physical Dimensions . . . . .	61
10.3.2	Installation and Grounding . . . . .	61
<b>11</b>	<b>RoHS and WEEE</b>	<b>62</b>
<b>12</b>	<b>Declaration of Conformity</b>	<b>63</b>

# 1 Imprint

**Meinberg Funkuhren GmbH & Co. KG**  
Lange Wand 9, 31812 Bad Pyrmont, Germany

Phone: + 49 (0) 52 81 / 93 09 - 0

Fax: + 49 (0) 52 81 / 93 09 - 230

Website: <https://www.meinbergglobal.com>

Email: [info@meinberg.de](mailto:info@meinberg.de)

Date: September 24, 2021

## 2 Important Safety Information

### 2.1 Important Safety Information and Safety Precautions

The following safety information must be observed whenever the device is being installed or operated. Failure to observe this safety information and other special warnings or operating instructions in the product manuals constitutes improper usage and may violate safety standards and the manufacturer's requirements.



Depending on the configuration of your device or installed options, some information may not specifically apply to your device.



The device satisfies the requirements of the following EU regulations: EMC Directive, Low Voltage Directive, RoHS Directive and—where applicable—the Radio Equipment Directive.

If a procedure is marked with the following signal words, you may only proceed with it if you have understood and fulfilled all requirements. Hazard notices and other relevant information are classified and indicated as such in this manual according to the following system:



#### **DANGER!**

This signal word indicates a hazard with a high risk level. Such a notice refers to a procedure or other action that will very likely result in serious injury or even death if not observed or if improperly performed.



#### **WARNING!**

This signal indicates a hazard with a medium risk level. Such a notice refers to a procedure or other action that may result in serious injury or even death if not observed or if improperly performed.



#### **CAUTION!**

This signal word indicates a hazard with a low risk level. Such a notice refers to a procedure or other action that may result in minor injury if not observed or if improperly performed.















#### **ATTENTION!**

This signal word refers to a procedure or other action that may result in product damage or the loss of important data if not observed or if improperly performed.

## 2.2 Used Symbols

The following symbols and pictograms are used in this manual. Pictograms are used in particular to indicate potential hazards in all hazard categories.

Symbol	Beschreibung / Description
	IEC 60417-5031 Gleichstrom / <i>Direct current</i>
	IEC 60417-5032 Wechselstrom / <i>Alternating current</i>
	IEC 60417-5017 Erdungsanschluss / <i>Earth (ground) terminal</i>
	IEC 60417-5019 Schutzleiteranschluss / <i>Protective earth (ground) terminal</i>
	ISO 7000-0434A Vorsicht / <i>Caution</i>
	IEC 60417-6042 Vorsicht, Risiko eines elektrischen Schlages / <i>Caution, risk of electric shock</i>
	IEC 60417-5041 Vorsicht, heiße Oberfläche / <i>Caution, hot surface</i>
	IEC 60417-6056 Vorsicht, Gefährlich sich bewegende Teile / <i>Caution, moving parts</i>
	IEC 60417-6172 Trennen Sie alle Netzstecker / <i>Disconnect all power connectors</i>
	IEC 60417-5134 Elektrostatisch gefährdete Bauteile / <i>Electrostatic Discharge Sensitive Devices</i>
	IEC 60417-6222 Information generell / <i>General information</i>
	2012/19/EU Dieses Produkt fällt unter die B2B Kategorie. Zur Entsorgung muss es an den Hersteller übergeben werden. <i>This product is handled as a B2B-category product. To ensure that the product is disposed of in a WEEE-compliant fashion, it must be returned to the manufacturer.</i>

## 2.3 Product Documentation

Detailed product documentation is provided on a USB flash drive delivered with the system. The manuals can also be downloaded from the Meinberg website at <https://www.meinbergglobal.com>, where you can enter your system name into the search box at the top of the page to find the relevant manual. Alternatively, contact Meinberg Support for further assistance.

The "Docs & Support" tab on the Web Interface also provides user manuals for time server administrators.



This manual contains important safety instructions for the installation and operation of the device. Please read this manual thoroughly before using the device.

This device may only be used for the purpose described in this manual. In particular, the specified operating limits of the device must be heeded. The person setting up the device is responsible for safety matters in relation to any larger system in which the device is installed!

Failure to observe these instructions may have an adverse impact on device safety!

Please keep this manual in a safe place.

This manual is only intended to be used by qualified electricians, or by persons who have been appropriately instructed by a qualified electrician and who are familiar with applicable national standards and with safety rules & regulations. This device may only be installed, set up, and operated by qualified personnel.



## 2.4 Safety during Installation



### WARNING!

#### Pre-Operation Procedures and Preparation for Use

This mountable device has been designed and examined in accordance with the requirements of the standard IEC 62368-1 "Audio/Video, Information and Communication Technology Equipment - Part 1: Safety Requirements".

When the mountable device is to be used as part of a larger unit (e.g., electrical enclosure), there will be additional requirements in the IEC 62368-1 standard that must be observed and complied with. General requirements regarding the safety of electrical equipment (such as IEC, VDE, DIN, ANSI) and applicable national standards must be observed in particular.

The device has been developed for use in the industrial sector or in home environments and may only be used in such environments. In environments at risk of high environmental conductivity ("high pollution degree" according to IEC 60664-1), additional measures such as installation of the device in an air-conditioned electrical cabinet may be necessary.

#### Transport, Unpacking, Installation

If the unit has been brought into the usage area from a cold environment, condensation may develop; in this case, wait until the unit has adjusted to the temperature and is completely dry before setting it up.

When unpacking & setting up, and before operating the equipment, be sure to read the information on installing the hardware and the specifications of the device. These include, for example, dimensions, electrical characteristics, or necessary environmental conditions.

Fire safety standards must be upheld with the device in its installed state.

The device must not be damaged in any way when mounting it. In particular, holes must not be drilled into the housing.

For safety reasons, the device with the highest mass should be installed at the lowest position in the rack. Further devices should be installed from the bottom, working your way up.

The device must be protected against mechanical & physical stresses such as vibration or shock.



### Connecting Data Cables

Do not connect or disconnect data cables during a thunderstorm, as doing so presents a risk in the event of a lightning strike.

The device cables must be connected or disconnected in the order specified in the user documentation for the device. Cables should always be held by the connector body when connecting or disconnecting them. Never pull a connector out by pulling on the cable. Doing so may cause the plug to be detached from the cable or cause damage to the plug itself.

Cables must be installed so that they do not represent a health & safety hazard (e.g., tripping) and are not at risk of damage (e.g., kinks).

### Connecting the Power Supply

This equipment is operated at a hazardous voltage. Failure to observe the safety instructions in this manual may result in serious injury, death or property damage.

Before the device is connected to the power supply, a grounding conductor must be connected to the earth terminal of the device.

The power supply should be connected with a short, low-inductance cable.

Before operation, check that all cables and lines work properly and are undamaged. Ensure in particular that the cables do not have kinks, that they are not wound too tightly around corners, and that no objects are placed on the cables.

Ensure that all connections are secure—make sure that the lock screws of the power supply plug are tightened when using a 3-pin MSTB or 5-pin MSTB connector (see diagram, LANTIME M300 power supply).

5-Pin MSTB Connector

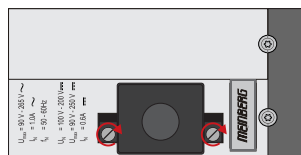

3-Pin MSTB Connector

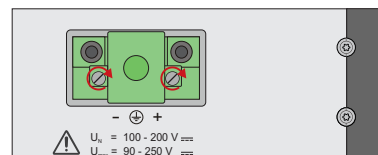

Faulty shielding or cabling and improperly connected plugs are a health & safety risk (risk of injury or death due to electrical shock) and may damage or even destroy your Meinberg device or other equipment.

Ensure that all necessary safety precautions have been taken. Connect all cables to the device only while the device is de-energized before turning on the power. Observe the safety instructions on the device itself (see safety symbols).

The metal chassis of the device is grounded. When installing the device in an electrical enclosure, it must be ensured that adequate clearance is provided, creepage distances to adjacent conductors are maintained, and that there is no risk of short circuits.

In the event of a malfunction or if servicing is required (e.g., damage to the chassis or power cable, ingress of fluids or foreign objects), the power supply may be cut off.

Please address any questions regarding your building's electrical, cable or antenna installations to the person or department responsible for that installation within your building.

AC Power Supply	DC Power Supply
<ul style="list-style-type: none"> <li>• The device is a Protection Class 1 device and may only be connected to a grounded outlet (TN system).</li> <li>• For safe operation, the installation must be protected by a fuse of a rating not exceeding 16 A and equipped with a residual-current circuit breaker in accordance with applicable national standards.</li> <li>• The disconnection of the appliance from the mains power supply must always be performed from the mains socket and not from the appliance itself.</li> <li>• Mains-powered appliances are equipped with a safety-tested mains cable designed for use in the country of operation and may only be connected to a grounded shockproof socket, otherwise electric shock may occur.</li> <li>• Make sure that the mains socket on the appliance or the mains socket of the house installation is readily accessible for the user so that the mains cable can be pulled out of the socket in an emergency.</li> </ul>	<ul style="list-style-type: none"> <li>• In accordance with IEC 62368-1, it must be possible to disconnect the appliance from the supply voltage from a point other than the appliance itself (e.g., from the primary circuit breaker).</li> <li>• The power supply plug may only be fitted or dismantled while the appliance is isolated from the power supply (e.g., disconnected at the primary circuit breaker).</li> <li>• Supply cables must be adequately secured and have an adequate wire gauge size.</li> </ul> <p style="text-align: center;"><i>Connection Cable Wire Gauge:</i>  <math>1\text{ mm}^2 - 2.5\text{ mm}^2</math>  17 AWG – 13 AWG</p> <ul style="list-style-type: none"> <li>• The power supply of the device must have a suitable disconnection mechanism such as a switch. This disconnection mechanism must be readily accessible in the vicinity of the appliance and marked accordingly as a cut-off mechanism for the appliance.</li> </ul>

## 2.5 Connection of Protective Earth Conductor/Grounding



ATTENTION!



In order to ensure that the device can be operated safely and to meet the requirements of IEC 62368-1, the device must be correctly connected to the protective earth conductor via the protective earth connection terminal.



If an external earth terminal is provided on the housing, it must be connected to your bonding busbar (grounding busbar). The parts required to attach the device to a grounding busbar are not included with the shipped product.

**Note:**

Please use a grounding cable with a core cross-section of  $\geq 1.5 \text{ mm}^2$   
Always ensure that the connection is properly crimped!

## 2.6 Safety during Operation



### WARNING!

#### Avoiding Short-Circuits

Protect the device against all ingress of solid objects or liquids. Ingress presents a risk of electric shock or short-circuiting!

#### Ventilation Slots

Ensure that the ventilation slots are clean and uncovered at all times. Blocked ventilation slots may cause heat to be trapped in the system, resulting in overheating. This may cause your device to malfunction or fail.

#### Appropriate Usage

The device is only deemed to be appropriately used and EMC limits (electromagnetic compatibility) are only deemed to be observed if the chassis cover is properly fitted (thus ensuring that the device is properly cooled, fire-safe, and shielded against electrical, magnetic and electromagnetic fields).



#### Switching the Device Off in the Event of a Malfunction or when Repairs are Required

It is not sufficient to simply switch off the device itself in order to disconnect the power supply. If the device is malfunctioning, or if repairs become necessary, the device must be isolated from all power supplies immediately.

#### **To do so, follow the procedure below:**

- Switch off the device from the unit itself.
- Pull out all power supply plugs.
- Inform the person or department responsible for your electrical installation.
- If your device is connected to an Uninterruptible Power Supply (UPS), it will remain operational even after pulling the UPS power cable from the mains socket. In this case, you will need to shut down your UPS in accordance with the user documentation of your UPS system.

## 2.7 Safety during Maintenance



### WARNING!

The device must never be opened. Repairs to the device may only be performed by the manufacturer or by authorized personnel. Improper repairs may expose the user to considerable safety risks (electric shock, fire hazard).

Opening the device or individual device components in an unauthorized fashion may also expose the user to considerable risks and invalidate your warranty. Meinberg Funkuhren accepts no liability for consequences arising from such unauthorized actions.



Danger from moving parts—do not touch moving parts.



Parts of the device may become very hot during operation. Do not touch these surfaces! If necessary, switch off the device before installing or removing any equipment, and allow it to cool down.

## 2.8 Handling of Batteries



### WARNING!

The lithium battery on the receiver modules has a life of at least ten years. Should it be necessary to replace it, please note the following:

Improper handling of the battery can lead to an explosion or to a leakage of flammable liquids or gases.

- Never short-circuit the battery.
- Never attempt to recharge the battery.
- Never throw the battery into a fire.
- The battery must only be exposed to the barometric pressure range specified by the battery manufacturer.
- The battery must only ever be replaced with one of the same type or a comparable type recommended by the manufacturer. The battery must only be replaced by the manufacturer or an authorized technician.
- Never dispose of the battery in a mechanical crusher or shredder, or in an open fire or furnace.
- Please consult your local waste disposal regulations for information on how to dispose of hazardous waste.



### ATTENTION!

The battery is used to power components such as the RAM and the reserve real-time backup clock for the reference clock.

If the battery voltage drops below 3 V DC, Meinberg recommends having the battery replaced. If the battery voltage drops below the specified minimum, the following behavior may be observed in the reference clock:

- The reference clock may have the wrong date or wrong date upon power-up
- The reference clock repeatedly starts in Cold Boot mode
- Some of the configurations saved for the reference clock may be lost

## 2.9 Cleaning and Care



### ATTENTION!

Never clean the device using liquids! Water ingress is a significant safety risk for the user (e.g., electric shock).

Liquids can cause irreparable damage to the electronics of the device! The ingress of liquids into the device chassis may cause short circuits in the electronic circuitry.

Only clean with a soft, dry cloth. Never use solvents or cleaners.

## 2.10 Prevention of ESD Damage



### ATTENTION!

An ESDS device (electrostatic discharge-sensitive device) is any device at risk of damage or malfunction due to electrostatic discharges (ESD) and thus requires special measures to prevent such damage or malfunction. Systems and modules with ESDS devices usually bear the following symbol:



### Symbol Indicating Devices with ESDS Components

The following measures will help to protect ESDS components from damage and malfunction.

#### When preparing to dismantle or install devices:

Ground your body (for example, by touching a grounded object) before touching sensitive devices.

Ensure that you wear a grounding strap on your wrist when handling such devices. These straps must in turn be attached to an uncoated, non-conductive metal part of the system.

Use only tools and devices that are free of static electricity.

#### When transporting devices:

Devices must only be touched or held by the edges. Never touch any pins or conductors on the device.

#### When dismantling or installing devices:

Avoid coming into contact with persons who are not grounded. Such contact may compromise your connection with the earth conductor and thus also compromise the device's protection from any static charges you may be carrying.

#### When storing devices:

Always store devices in ESD-proof ("antistatic") bags. These bags must not be damaged in any way. ESD-proof bags that are crumpled or have holes cannot provide effective protection against electrostatic discharges.

ESD-proof bags must have a sufficient electrical resistance and must not be made of conductive metals if the device has a lithium battery fitted on it.



## 2.11 Return of Electrical and Electronic Equipment



### ATTENTION!

**WEEE Directive on Waste Electrical and Electronic Equipment 2012/19/EU**  
(WEEE Waste Electrical and Electronic Equipment)

#### Waste Separation

Product Category: According to the device types listed in Annex I of the WEEE Directive, this product is classified as "IT and Telecommunications Equipment".



This product satisfies the labeling requirements of the WEEE Directive. The product symbol on the left indicates that this electronic product must not be disposed of in domestic waste.

#### Return and Collection Systems

When disposing of your old equipment, please use the national return or collection systems available to you. Alternatively, you may contact Meinberg, who will provide further assistance.

The return of electronic waste may not be accepted if the device is soiled or contaminated in such a way that it potentially presents a risk to human health or safety.

#### Return of Used Batteries

The EU Battery Directive prohibits the disposal of batteries marked with the WEEE trashcan symbol above in household waste.

## 3 General Information about LANTIME

LANTIME stands for Local Area Network **T**ime Server. The LANTIME provides an absolute and highly precise time reference in a TCP/IP network (stratum 1 server). The time is made available to all NTP clients via the NTP protocol (Network Time Protocol) and allows easy integration of an absolute time reference into an existing network.

The individual LANTIME variants differ mainly in the time reference source used. An external radio clock, a built-in GPS, GNSS (GPS, GLONASS, Galileo, BeiDou), or GNS-UC (only GPS and Galileo) satellite receiver, an IRIG time code receiver, a long-wave radio receiver (DCF77, MSF, WWVB), external NTP servers, or a hybrid DCF77/GNSS receiver system can be used as a time reference source. A GNSS-synchronized LANTIME, for example, consists of a GNSS satellite receiver, a single-board computer with an integrated network card, and a power supply unit.

A simplified LINUX operating system is implemented on the single-board computer and is loaded from a flash disk during the boot phase. All settings can be made using eight pushbuttons and a display\*. The time server can also be remotely configured via network over SSH, FTP, or Telnet. An integrated web server provides access to the LANTIME via any standard web browser.

\* LANTIME M100 time servers do not have a display or function keys. Instead, these systems are configured and monitored via the LANTIME Web Interface, SSH, Telnet, or FTP.

# 4 Frequency Deviation Module - FDM

## 4.1 Overview

The FDM module is used to calculate the mains frequency and monitor frequency deviations in 50/60 Hz grids.

An upstream reference clock supplies a 10 MHz frequency, a serial time string and a pulse-per-second signal. These reference signals play a critical role in determining the accuracy of the measured values.

In addition to measurement of the mains frequency itself, the FDM module also uses the mains frequency to operate a separate clock referred to as Power Line Time (PLT). The difference between the PLT and the Reference Time (REF Time) is referred to as the Time Deviation (TD). The long-term accuracy of this TD is equivalent to that of the Reference Time and is therefore an accurate indicator of frequency stability.

## Configuration and Status Monitoring

There are extensive options for reconfiguring and monitoring the status of the FDM from the front panel display and the LANTIME Web Interface:

- Configuration of upper and lower limits of Power Line Frequency
- Configuration of alarm messages via email or SNMP traps when limits are exceeded
- Status monitoring of Power Line Frequency, Frequency Deviation, Reference Time, Power Line Time
- Ability to record frequency plots of the Power Line Frequency as well as the Time Deviation by using "SyncMon"
- Connection of up to 15 DU35K/FDM displays connected via network

## 4.2 Functional Principle

The mains supply for which the frequency is to be monitored is connected via an IEC 60320 C14 "kettle plug" power supply connector in the rear panel. The mains voltage is then filtered and stepped down. To ensure that a mains frequency of between 45 and 65 Hz is correctly detected, the mains voltage must be in a range of 70 to 270 V AC.

The sine wave signal is then fed into the module's microcontroller.

The PL Time is calculated by counting the power line cycles. Depending on the mains frequency (50 or 60 Hz), one second is added every 50 or 60 cycles. The PL Time needs to be initialized by synchronizing it against the Reference Time (REF Time), and this value is sent to the module based on the PPS signal and a serial time string from the internal reference clock. The difference between the PL Time and REF Time is calculated once a second, is referred to as the Time Deviation (TD) and is limited to +/- 1000 seconds.

## 4.3 Display String

The string is a sequence of 62 ASCII characters containing the frequency *F*, the frequency deviation *FD*, the REF Time, the Power Line Time *PL* Time and the Time Deviation *TD*, separated by a space character each. The string ends with the characters Carriage Return (ASCII code 0Dh) and Line Feed (ASCII code 0Ah). The letters displayed in italics are replaced by the calculated values whereas the other characters are part of the string:

*F:49.984\_FD:-00.016\_REF:15:03:30\_PLT:15:03:30.378\_TD:+00.378*<CR><LF>

The meaning of the string fields and values is as follows:

<i>F:49.984</i>	The measured Power Line Frequency with a resolution of 1 mHz
<i>FD:-00.016</i>	The Frequency Deviation between calculated and nominal frequency, with sign character (+/-), resolution: 1 mHz, maximum: +-09.999 Hz
<i>REF:15:03:30</i>	The Reference Time from the upstream clock (hours:minutes:seconds)
<i>PLT:15:03:30.378</i>	The Power Line Time, based on the Power Line Frequency, (hours:minutes:seconds.milliseconds)  Time adjustments such as Daylight Saving Time or leap seconds will not be accounted for by the PL Time!
<i>TD:+00.378</i>	The Time Deviation between REF Time and PL Time, signed value (+/-), resolution: 1 ms, maximum: +-999.999 s

## 4.4 FDM Technical Specifications

<b>Reference Clock</b>	10 MHz Oscillator Clock (TTL Level)
<b>Input Signals:</b>	Pulse-per-Second, Active High (TTL Level) Serial Time String (RS-232 or USB), Meinberg Standard Time String or Uni-Erlangen Time String Mains Voltage: 70–270 V, 30–80 Hz, max. 2.5 VA
<b>Outputs:</b>	2 Analog Outputs (optionally available in M300): -2.5 – +2.5 V, Resolution: 16-Bit Fail Output (TTL Level) Overflow Output (TTL Level)
<b>Interfaces:</b>	2 Serial RS-232 Ports - COM0, COM1 (optional), configurable:  Baud Rate: 300, 600, 1200, 2400, 4800, 9600 or 19200 Baud Framing: 7N2, 7E1, 7E2, 8N1, 8N2 or 8E1 Different FDM Strings Selectable
<b>Accuracy of Measurement:</b>	Frequency: Accuracy of Reference (10 MHz) $\pm 0.1$ mHz Time deviation: Accuracy of Reference (PPS) $\pm 1$ ms

## 5 Technical specifications 3U Chassis

**Housing** Chassis 19" / 3U

**Housing material** Aluminium

---

### Temperature range

**Operation** 0 ... 50 °C (32 ... 122 °F)

**Storage** -20 ... 70 °C (-4 ... 158 °F)

---

### Relative humidity

**Operation** 85 % max. (non-condensing)

---

### Operation height

**Operation** 2000 m / 6562 ft (above sea level)

---

**Acoustics** 0 dB (A)

**IP protection class** IP20

## Housing dimensions

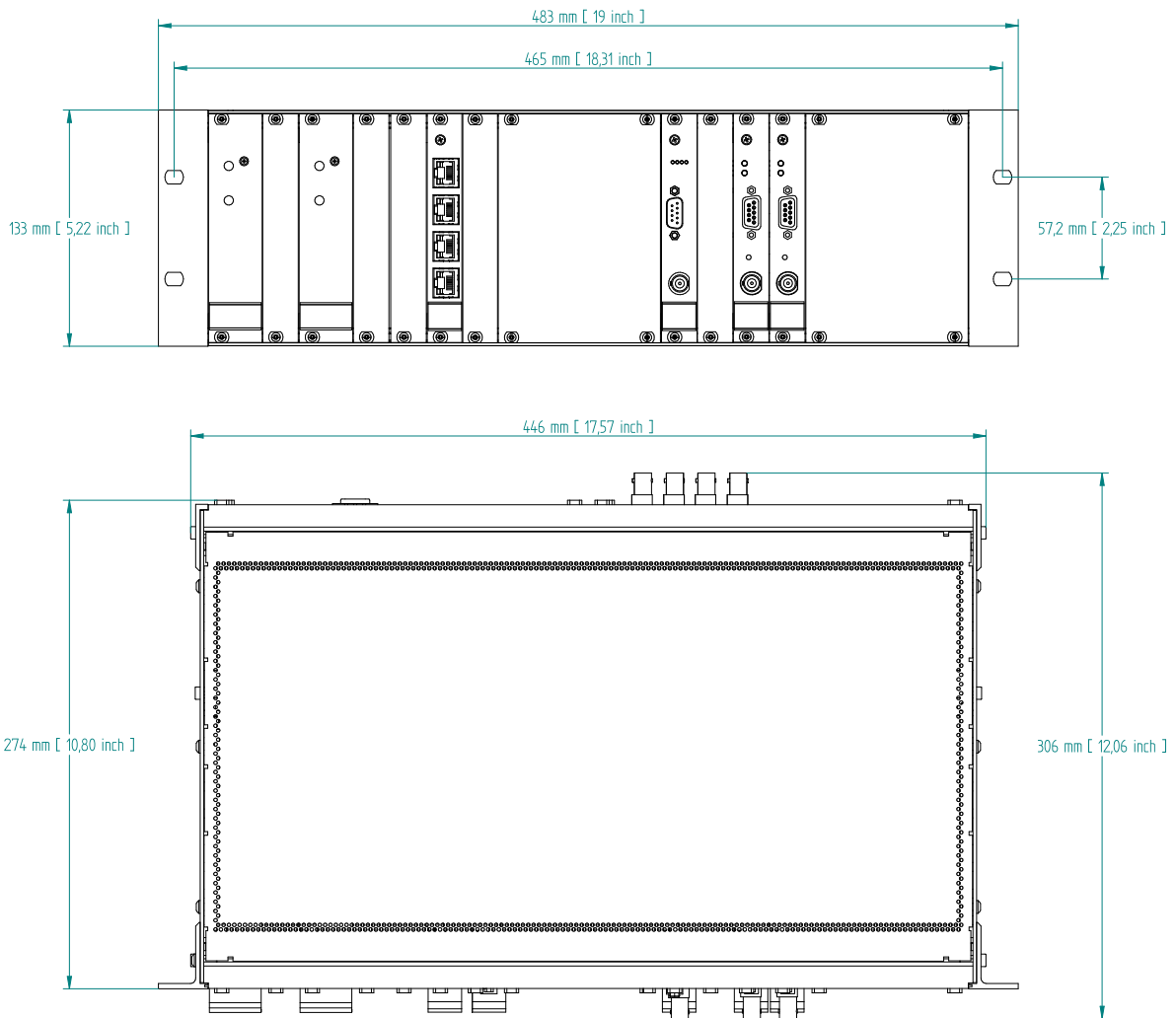

## 6 LANTIME M900 Front Connectors

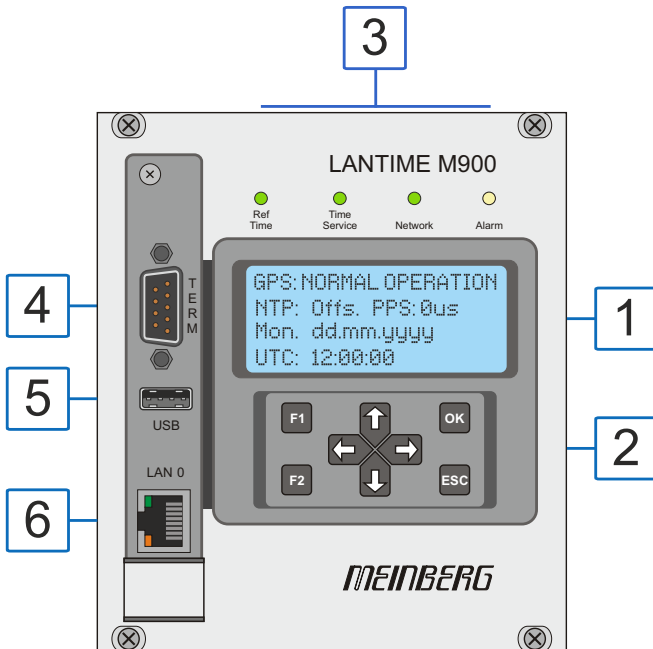

### 1.

The main menu is displayed after switching on the device and having completed the initialization phase. In the main menu the most important status information are displayed. In the top line of the display the operating mode of the reference clock / reference time is shown. Instead of "GPS: NORMAL OPERATION" the messages, "GPS: COLD BOOT", "GPS: WARM BOOT" or "GPS: UPDATE ALMANAC" can appear. In case the antenna connection is interrupted, the following message is shown: "GPS: ANTENNA FAULTY".

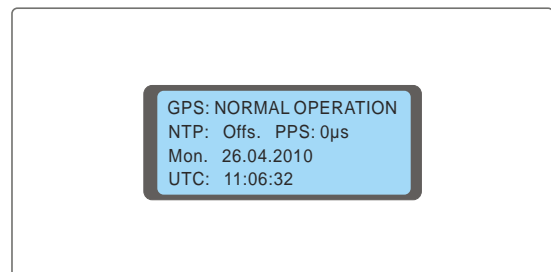

### 2.

By using the 4 arrows and the "ESC", "F1" and "F2" buttons of the keypad you can navigate through each menu in the display. You can always return to the main menu by pressing the "ESC" button several times.

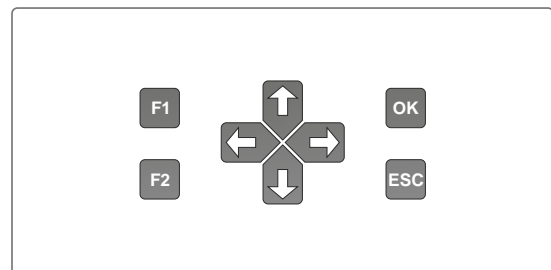



### 3.

#### "Ref. Time"

green: the reference clock (e.g. build-in GPS180) provides a valid time  
 red: the reference clock does not provide a valid time

#### "Time Service"

green: NTP is synchronized to the reference clock, e.g. GPS180  
 red: NTP is not synchronized or switched to the "local clock"

#### "Network"

green: all monitored network interfaces are connected ("Link up")  
 red: at least one of the monitored network interfaces is faulty

#### "Alarm"

off: no error  
 red: general error

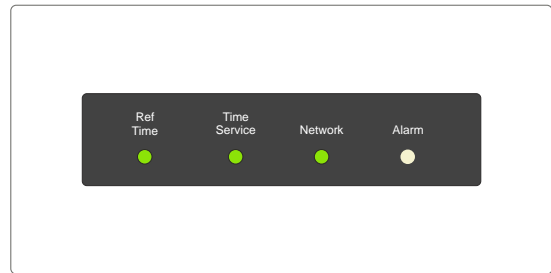

### 4.

To connect a serial terminal use the 9pin SUBD RS-232 connector in the front panel. Via the serial terminal connection it is possible to configure the parameters with a terminal program. To establish a connection between the LANTIME and a PC, use a NULL-MODEM cable. Configure your terminal program with 38400 Baud, 8 Databits, no parity and one Stopbit ( 8N1). The terminal emulation has to be set to VT100. After connecting to the time server the login message will be displayed. Enter user name and password:

Default User: *root*; Password: *timeserver*

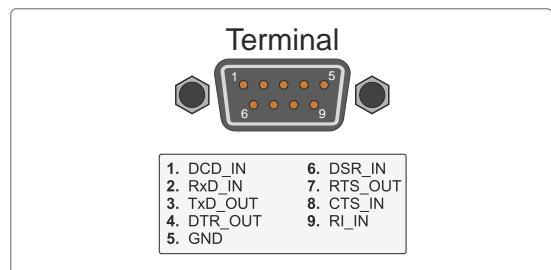

### 5.

All devices of the LANTIME M-Series dispose a USB interface, which can be used to plug in a USB Stick. The USB Stick can be deployed for the following tasks:

- to lock the keys on the LC-Display, to prevent unauthorized access
- to save the LANTIME configuration
- to transfer the configuration between several LANTIMES
- to save log files

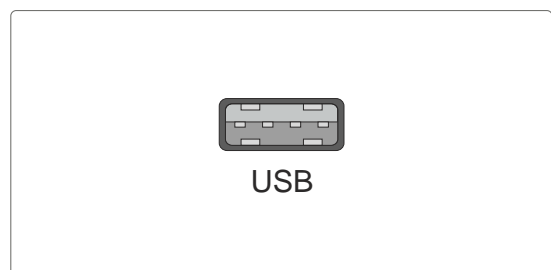

## 6.

### 10/100BASE-T Network Port (IEEE 803.2)

<b>Signal:</b>	100BASE-T
<b>Data transmission rate:</b>	10/100 Mbit/s
<b>Connection type:</b>	8P8C (RJ45)
<b>Cable:</b>	Copper twisted pair, e.g. CAT 5.0
<b>Duplex Modes:</b>	Half/Full/Autonegotiaton

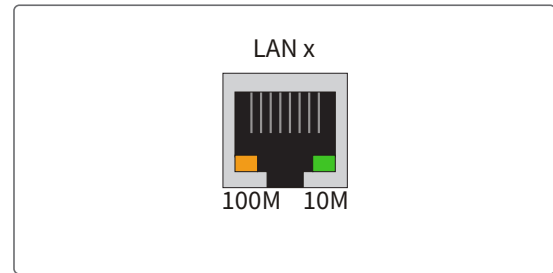

## 6.1 GPS Receiver

### Description

The GPS180 is using the "Standard Positioning Service" SPS. Navigation messages coming in from the satellites are decoded by the GPS180 microprocessor in order to track the GPS system time. Compensation of the RF signal's propagation delay is done by automatic determination of the receiver's geographical position. A correction value computed from the satellites' navigation messages drift caused by the board's oven controlled master oscillator (OCXO) and automatically compensates the OCXO's aging. The last state of this value is restored from the battery buffered memory at power-up.

### Technical specification

<b>Receiver type:</b>	12 channel GPS C/A-code receiver
<b>Accuracy of pulse outputs:</b>	Depends on oscillator option: < +-100 ns (TCXO, OCXO LQ) < +-50 ns (OCXO-SQ, -MQ, -HQ, -DHQ)
<b>Antenna Cable:</b>	shielded coax
<b>Cable length:</b>	max. 300 m to RG58, max. 700 m to RG213
<b>Antenna Connector:</b>	BNC female
<b>Input GPS:</b>	Antenna circuit 1000 V DC insulated
<b>Mixed frequency</b>	
Reference clock to antenna (GPS converter):	10 MHz <sup>1)</sup>
<b>Intermediate frequency</b>	
Antenna (GPS converter) to reference clock:	35.4 MHz <sup>1)</sup>

<sup>1)</sup> These frequencies are transferred via the antenna cable

### Power Requirements

**of the Antenna:** 15 V, 100 mA (via antenna cable)



### LED Indicators

#### Freq. LED

blue: Initialisation phase  
green: "warmed up" - oscillator is adjusted

#### Ant. LED

red: no synchronization resp. no antenna connected  
or short circuit on the antenna line  
green: antenna connected and clock is synchronized

#### Lock LED

green: positioning complete

#### Fail LED

red: no synchronization

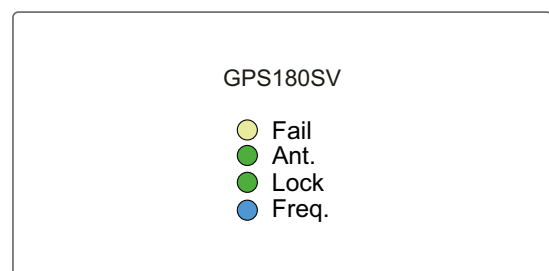

## 6.2 Frequency Deviation Monitor (FDM)

### Front Panel Layout

The 61 mm-wide front panel provides four status LEDs, two buttons and an eight-digit alphanumeric LED display.

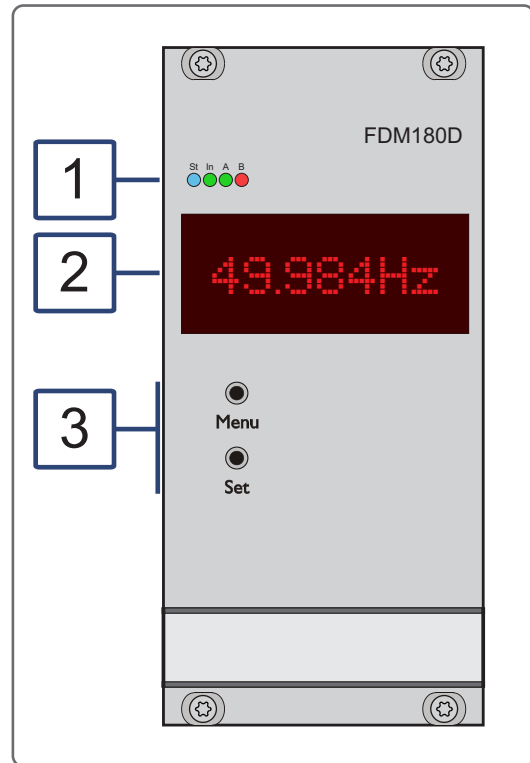

The outputs for the FDM are located on the rear panel. Please refer to the chapter LANTIME M900 Rear Connectors for more detailed specifications for these outputs.

### Serial COM Ports

The FDM provides two serial RS-232 interfaces: COM0 and COM1. Both of these ports can output values and measurements in the form of a configurable string.

### EEPROM

The nonvolatile EEPROM is used to store the configuration of the FDM so that the device is ready for use right away after a restart and does not need to be reconfigured. The two buttons on the front panel and the LED display can be used to configure the FDM (see Setup Submenu).

## 6.2.1 FDM Push Buttons

Measurement and status information can be displayed using the two buttons. The **Menu** button is used to cycle through various menu entries while the **Set** button is used to select the entry and display its content. In the Setup submenu, the buttons are also used to configure the FDM's operating parameters.

## 6.2.2 FDM Status LEDs

### Status Indicators

LED St: Status of the FDM  
 LED In: Status of the backplane output signals  
 LED A: Status of the FDM Frequency Deviation (FD)  
 LED B: Status of the FDM Time Deviation (TD)

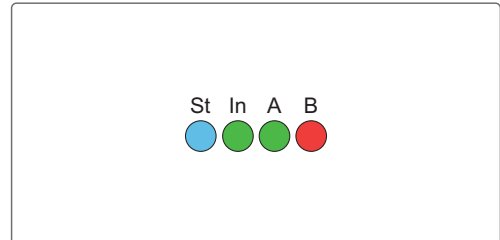

The LEDs use the following colors to signal messages:

### LED St:

Blue During initialization  
 Green During operation

### LED In:

Shows status after initialization

Green Accurate (accuracy of  $\leq 200$  ns to reference)  
 Flashing Green Timesyncing  
 Yellow Quality of the reference signal insufficient  
 Red Reference signal not available / FDM is not synchronized

### LED A - Status Output 1-2:

1 second red -> 1 second yellow -> 1 second green -> 1 second off

Green FD (Frequency Deviation) within configured limits  
 Red FD overflow

### LED B - Status Output 3-4:

1 second red -> 1 second yellow -> 1 second green -> 1 second off

Green TD (Time Deviation) within configured limits  
 Red TD overflow

### 6.2.3 FDM Display

The eight-digit alphanumeric LED display is used to display the measurements and values. It is also used to display and reconfigure the operating parameters through the Setup menu and to display status information.



# 7 LANTIME M900 Rear Connectors

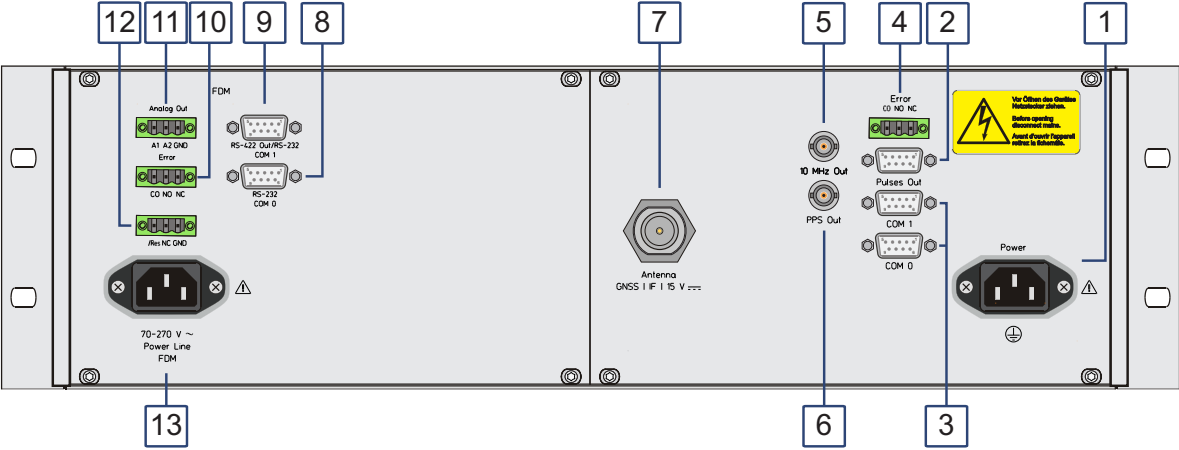

## 7.1 Power Connector

Connector Type: IEC320 AC inlet

### Input Parameter

Nominal Voltage Range:	$U_N$	=	100-240 V~
	$U_N$	=	100-200 V ---
Maximum Voltage Range:	$U_{max}$	=	90-265 V~
	$U_{max}$	=	90-250 V ---
Nominal Current:	$I_N$	=	0.30 A
Nominal Frequency Range:	$f_N$	=	50-60 Hz
Maximum Frequency Range:	$f_{max}$	=	47-63 Hz

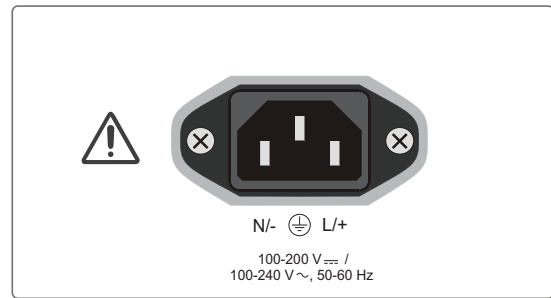

### Output Parameter

Maximum Power:	$P_{max}$	=	30 W
Max. Heat Emission:	$E_{therm}$	=	108.00 kJ/h (102.37 BTU/h)



#### WARNING!

This equipment is operated at a hazardous voltage.



#### Danger of death from electric shock!

- This device must be connected by qualified personnel (electricians) only.
- Never handle exposed terminals or plugs while the power is on.
- All connectors must provide protection against contact with live parts in the form of a suitable plug body!
- Note: Always ensure that wiring is safe!
- Important: The device must be grounded by means of a connection with a correctly installed protective earth conductor (PE).



## 7.2 Pulses Output

**Connector Type::** 9-Pin D-Sub female

**Cable:** shielded data line

**Pin Layout:**

Pin 1: PPS (Pulse Per Second)  
 Pin 3: PPM (Pulse Per Minute)  
 Pin 5: GND (ground)  
 Pin 6: F.Synth  
 Pin 7: CAP0  
 Pin 8: CAP1  
 Pin 9: GND (ground)

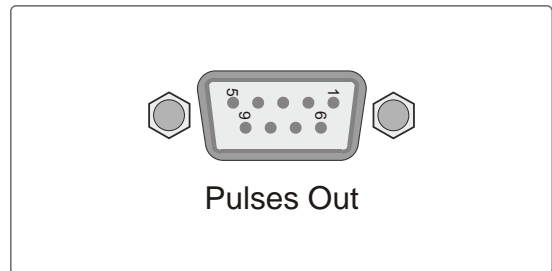

## 7.3 RS-232 COMx Timestring

**Data transfer** serial

**Data transfer** 19200 / 8N1 (default)

**Time string** Meinberg Standard (default)

**Assignment:**

Pin 2: TxD (transmit)  
 Pin 3: RxD (receive)  
 Pin 5: GND (ground)

**Connection type:** D-Sub female 9pol.

**Cable:** data cable (shielded)  
 PC connector 1:1

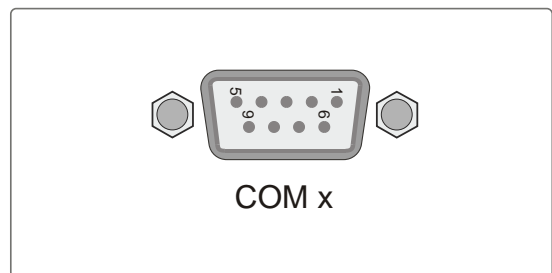

## 7.4 Error Relay

A 3-pin MSTB connector labeled "Error" is located on the rear panel of the device. This 0 V ("dry") relay output is connected to the TTL TIME\_SYNC output of the reference clock (GPS, PZF, TCR, etc.) Normally, when the internal reference clock has been synchronized to its source (GPS, DCF77, or IIG), this relay will switch to "NO" (Normally Open) mode. However, if there is a poor antenna signal or the device has been switched off, the relay will fall back to "NC" (Normally Closed) mode.

This relay can also be switched to a "NO" state using messages, providing a variety of switch states at this output.

### Technical Specifications

<b>Max. Switching Voltage:</b>	125 V DC 140 V AC
<b>Max. Switching Current:</b>	1 A
<b>Max. Switching Load:</b>	DC 30 W AC 60 VA
<b>UL/CSA Switching Current:</b>	0.46 A 140 V AC 0.46 A 65 V DC 1 A 30 V DC
<b>Response Time:</b>	Approx. 2 ms

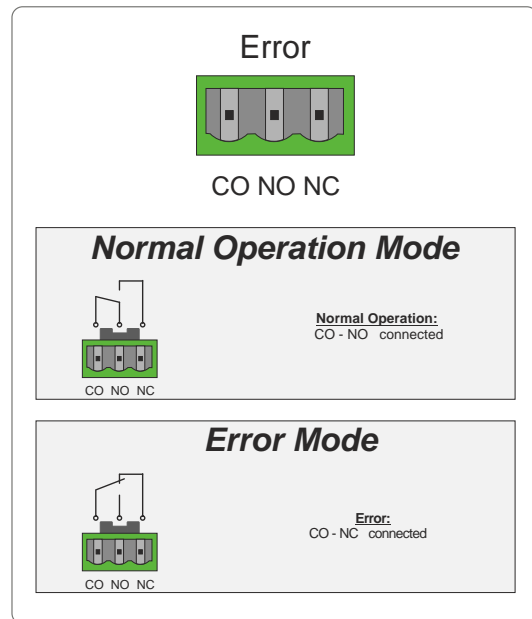

#### WARNING!

This equipment is operated at a hazardous voltage.



#### Danger of death from electric shock!

- Never work with open terminals and plugs while the power is on!
- When handling the connectors of the error relay cable, always disconnect both ends of the cable from their respective devices!
- Hazardous voltages may be passing through the terminal of the fault signal relay! Never handle the fault signal relay terminal while the signal voltage is present!

## 7.5 10 MHz Frequency Output

<b>Output Signal:</b>	10 MHz Frequency
<b>Signal Level:</b>	TTL, 2.5 V, 50 $\Omega$ Termination
<b>Connection Type:</b>	BNC Female
<b>Cable:</b>	Coaxial Cable, Shielded

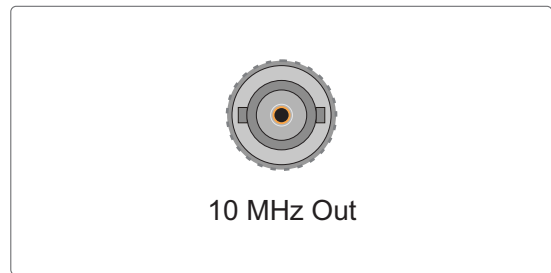

## 7.6 Pulse per Second Output

<b>Output Signal:</b>	PPS (Pulse per Second)
<b>Signal Level:</b>	TTL 2.5 V, 50 $\Omega$ Termination
<b>Pulse Length:</b>	200 ms
<b>Connector Type:</b>	BNC Female
<b>Cable:</b>	Coaxial Cable, Shielded

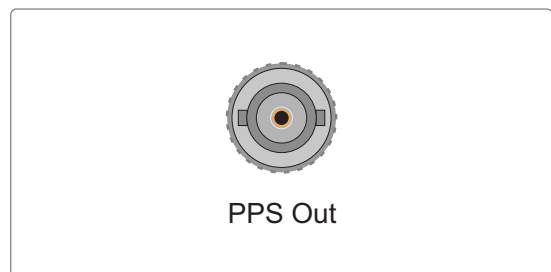

## 7.7 Antenna Input: GPS Reference Clock

**Antenna Input**  
**GPS180:** Antenna Circuit, Electrically Insulated

**Dielectric Strength:** 1000 V

**Receiver Type:** GPS  
 12-Channel GPS C/A Code Receiver

**Mixed Frequency**  
 Reference Clock to Antenna  
 (GPS Converter): 10 MHz <sup>1</sup>

**IF Frequency**  
 Antenna (GPS Converter)  
 to Reference Clock: 35.4 MHz <sup>1</sup>

<sup>1</sup> These frequencies are transferred via the antenna cable

**Power Requirements of the Antenna:** 15 V, 100 mA (Via Antenna Cable)

**Connection Type:** BNC Female/Type-N Female

**Cable Type:** Coaxial Cable, Shielded

**Cable Length:** Max. 300 m to RG58,  
 Max. 700 m to RG213

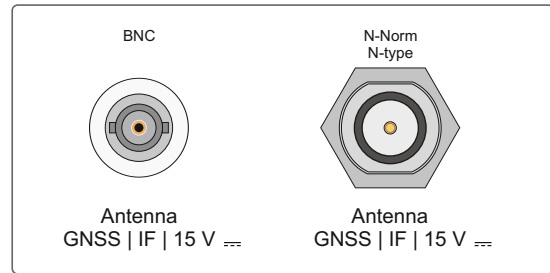

### WARNING!

Do not work on the antenna system during thunderstorms!



### Danger of death from electric shock!

- Do not carry out any work on the antenna system or the antenna cable if there is a risk of lightning strike.
- Do not carry out any work on the antenna system if it is not possible to maintain the prescribed safe distance to exposed lines and electrical substations.

## 7.8 FDM COM0: RS-232

Data transfer:	serial
Baudrate/framing:	19200 / 8N1 (default)
FDM Sting:	FDM Standard (default)
Assignment:	
Pin 2:	TxD (transmit)
Pin 3:	RxD (receive)
Pin 5:	GND (ground)
Connector:	D-SUB 9pin female
Cable:	shielded data line

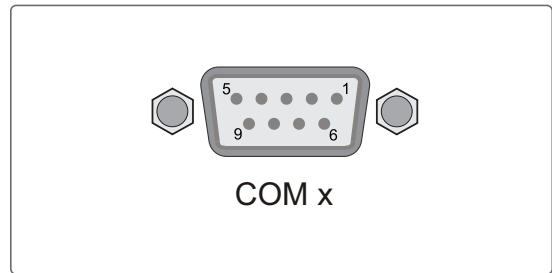

### WARNING!

This equipment is operated at a hazardous voltage.



### Danger to life due to electrical shock!

- Never work with open terminals and plugs while the power is on!
- When working on the connectors of the interface cable, always remove both sides of the cable from the respective devices!

The device is equipped with two potential-free and isolated serial interfaces. In the event of a fault in a connected device, dangerous voltages can occur at the signal lines of the serial interfaces.

## 7.9 FDM COM 1: RS-232/RS-422

<b>Data transfer:</b>	serial
<b>Baudrate/framing:</b>	19200 / 8N1 (default)
<b>FDM Sting:</b>	FDM Standard (default)
<b>Assignment:</b>	
Pin 2:	RxD (receive)
Pin 3:	TxD (transmit)
Pin 5:	GND (ground)
Pin 7:	Tx + (RS422)
Pin 8:	Tx - (RS422)
<b>Connector:</b>	D-SUB 9pin female
<b>Cable:</b>	shielded data line PC connector (serial port) 1:1

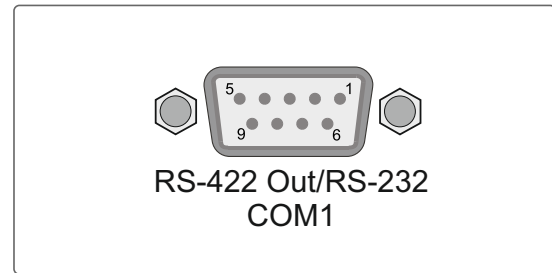

## 7.10 FDM Error Relay

In addition to the relay output of the reference clock, there is another potential-free relay output on the back of the M900/GPS above the FDM Power Line connector, which is controlled by the installed FDM.

If the monitored mains frequency is within the previously configured min. and max. frequency deviations, the relay switches and the relay contact "NO" is active. In case the mains frequency exceeds these predefined limits, the relay switches and the relay contact "NC" is active.

This relay can additionally be switched to the "NO" (Normally Open) state via the notifications. This means there are different switching states at this output.

### Technical specifications

**Switching voltage max.:** 125 V DC  
140 V AC

**Switching current max.:** 1 A

**Switching load max.:** DC 30 W  
AC 60 VA

**Switching current UL/CSA:** 0.46 A 140 V AC  
0.46 A 65 V DC  
1 A 30 V DC

**Response Time:** ca. 2 ms

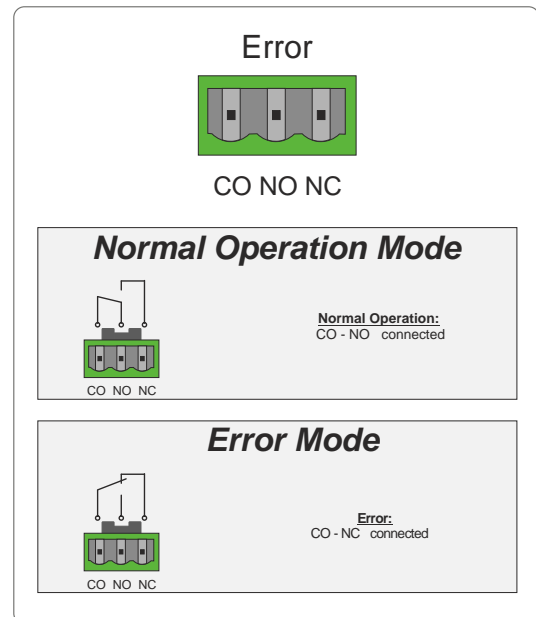

### WARNING!

This equipment is operated at a hazardous voltage.



### Danger of death from electric shock!

- Never work with open terminals and plugs while the power is on!
- When handling the connectors of the error relay cable, always disconnect both ends of the cable from their respective devices!
- Hazardous voltages may be passing through the terminal of the fault signal relay! Never handle the fault signal relay terminal while the signal voltage is present!

## 7.11 FDM Analog Outputs

**Outputs:** 2 analog outputs: -2.5 V ... 2,5 V,  
Fail output (TTL level)  
Overflow output (TTL level)

**Amplitude resolution:** 16 bit, 65535 steps

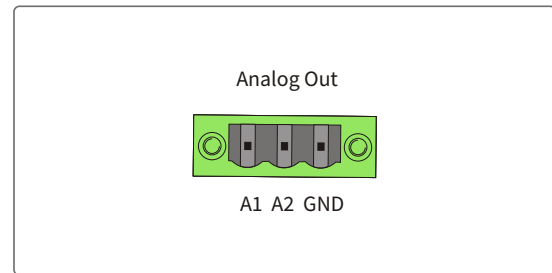

For each output, either the frequency deviation or the difference time can be selected as the display variable.

## 7.12 FDM Power Line

**Input Voltage Range:** 70-270 V AC

**Connector:** Power Line: IEC 60320 C14 AC

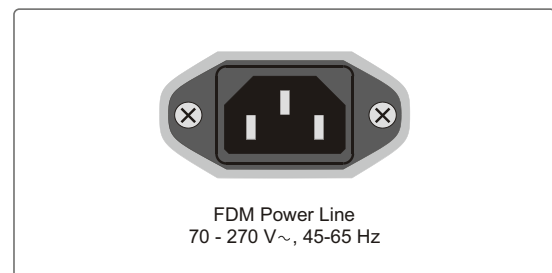



## 8 Configuration and Status of the FDM

This chapter shows how the front control panel is used to both configure the FDM and obtain information on its status.

The web interface provides an alternative and much more feature-rich method of configuring and monitoring the status of the FDM module. Please refer to the LTOS manual for more detailed information on the individual menus and configuration processes in the web interface.

### 8.1 Menu Entry: Frequency

Pressing the **Set** button under this menu item displays the current calculated power-line frequency with a resolution of 0.001 Hz (this is the value displayed by default when the module is powered up). The **Menu** button is used to return to the main menu.



### 8.2 Menu Entry: Frequency Deviation

Pressing the **Set** button under this menu item shows the deviation of the power-line frequency from the nominal frequency (50 or 60 Hz, see "Menu Entry: Nominal Frequency"). The frequency deviation is a signed value with the same resolution and accuracy of the power-line frequency display. If the configured limits are exceeded, an error bit will be set (see Menu Entry: Error) and the "A" LED will show red. The **Menu** button is used to return to the main menu.



### 8.3 Menu Entry: REF Time

Pressing the **Set** button under this menu item displays the time as provided by the reference clock. The **Menu** button is used to return to the main menu.



## 8.4 Menu Entry: PL Time

Pressing the **Set** button under this menu item displays the power line time ("PL time"). The PL time is synchronized with the REF time upon power-up or reset and uses the mains frequency from that point as its timekeeping reference. Please note that this means any artificial time adjustments such as Daylight Saving Time or leap second adjustments will not be accounted for! The **Menu** button is used to return to the main menu.

A rectangular LCD display showing the text "PL Time" in a white, dot-matrix font on a dark background.A rectangular LCD display showing the time "15:03:30" in a white, dot-matrix font on a dark background.

## 8.5 Menu Entry: Time Deviation

Pressing the **Set** button under this menu item displays the time deviation, which is the difference between the REF time (which remains accurate) and the PL time (which is subject to drift after some time if not corrected). The displayed value is signed, has a resolution of 1 ms and has configurable limits. If these limits are exceeded, an error bit will be set (see "Menu Entry: Error") and the "B" LED will show red.

The Time Deviation is set to +00.000 s upon power-up or reset, but can be set to any value via the setup menu "TD Init". The long-term accuracy of the Time Deviation is equal to that of the Pulse-per-Second signal from the reference. The **Menu** button is used to return to the main menu.

A rectangular LCD display showing the text "Time Dev" in a white, dot-matrix font on a dark background.A rectangular LCD display showing the time deviation "+00.378s" in a white, dot-matrix font on a dark background.

## 8.6 Setup Submenu

This submenu is used to configure the FDM. In order to avoid unintentionally making changes to the device configuration, this submenu cannot be accessed by simply briefly pressing the **Set** button as you would have done with the other menu items. Instead, the submenu is accessed by holding down the **Set** button for a short time (for around a second) until the "\*" symbol appears alongside the text.



Setup \*

The **Menu** button is used from this point to cycle through all available setup submenu items that are used to configure the device; these in turn can be accessed using the **Set** button as described above. The following setup submenu items will appear in the listed order with each press of the **Menu** button.

### 8.6.1 Menu Entry: Nominal Frequency

The FDM frequency deviation monitor supports both 50 Hz and 60 Hz power grids. The relevant grid frequency is selected using this menu item.



Nom.Freq



50Hz

Pressing the **Set** button will display the current setting. From this point you can either press the **Menu** button to return to the setup submenu, or press the **Set** button again to modify the setting.

Pressing the **Set** button to modify the setting will cause the value to flash, which allows you to modify this setting using the **Set** button again. Once the desired value is displayed, holding down the **Menu** button briefly (for around a second) will store the configuration and return you to the setup submenu.

### 8.6.2 Menu Entry: Time Deviation Init

Upon power-up, the PL Time is synchronized with the REF Time, resulting in a Time Deviation of +00.000 seconds. However, if a different start-up value is required for any reason, this submenu can be used to set a default Time Deviation offset value in a range of -999.999 seconds and +999.999 seconds. The PL Time will then be calculated according to the new Time Deviation init offset value.



TD Init.



-01.256s

Pressing the **Set** button will display the current Time Deviation. From this point you can either press the **Menu** button to return to the Setup submenu, or press the **Set** button again to modify the setting.

The +/- sign of the Time Deviation value will begin to flash when the **Set** button is pressed. This sign can be changed using the **Set** button again. Once the sign has been changed successfully, press the **Menu** button briefly to move on to the first digit. This can be adjusted using the **Set** in the usual fashion, and the **Menu** button can be used to move onto the next digit.

Once all digits have been set for the desired Time Deviation value, the configuration is stored by briefly holding down the **Menu** button (for around one second). The FDM will now recalculate the corresponding PL Time and return you to the Setup submenu.

### 8.6.3 Menu Entry: COM Parameters (Par.COM0 and Par.COM1)

The two submenu items Par.COM0 and Par.COM1 can be used to configure the serial RS-232 ports COM0 and COM1.



Par.COM0



19.2 8N1

The parameters for the COM ports are adjusted using the **Menu** and **Set** buttons as previously described. The following settings are possible:

Baud rate: 300 / 600 / 1200 / 2400 / 4800 / 9600 / 19.2k  
 Frame format: 7N2 / 7E1 / 7E2 / 8N1 / 8N2 / 8E1

### 8.6.4 Menu Entry: COMx Mode (Mod.COM0 and Mod.COM1)

The two submenu items Mod.COM0 and Mod.COM1 can be used to select the repetition rate of the serial output strings for COM0 and COM1. The output mode is modified using the **Menu** and **Set** buttons as previously described.



Mod.COM1



per Sec.

The following settings are possible:

- per second (per Sec.)
- per minute (per Min.)
- on request (on Req.)

### 8.6.5 Menu Entry: Output String (Str.COM0 and Str.COM1)

The two menu items Str.COM0 and Str.COM1 can be used to select the format of the serial output strings for COM0 and COM1.



Str.COM0



STANDARD

The **Menu** and **Set** buttons are used to select the options as previously described. The following string formats are available:

- Standard FDM String (STANDARD)
- Short FDM String (SHORT)
- TTM1 (AREVA String) (TTM1)
- TTM2 (TPC-Siemens String) (TTM2)
- Standard (\*2) FDM String (STD.\*2)
- Comptime Extended FDM String (CT ext.)
- Fingrid (FINGRID)
- FDM3 (FDM3)
- FDM3USR (FDM3USR)

The format of the output strings is described in the chapter "Serial Output Strings".

## 8.6.6 Menu Entry: Freq. Deviation Limit

The frequency deviation limits are selected under this menu item. Whenever the frequency deviation exceeds this limit, the overflow error bit will be set (see Menu Entry: Error) and the "A" LED will show red. The value is changed using the **Menu** and **Set** buttons as previously described.



FDLimit



500mHz

The following settings are possible:

- $\pm 50$  mHz
- $\pm 500$  mHz
- $\pm 5$  Hz

When configuring the FDM via the LANTIME Web Interface, this value is not limited to the three values listed above and can be set to any arbitrary value. In this case, [remote] will appear on the display, as it otherwise may not be possible to display the configured value.

Line Frequency  
50 Hz

Min Frequency  
49900 mHz

Max Frequency  
50100 mHz

Max Negative Time Deviation  
1000000 ms

Max Positive Time Deviation  
1000000 ms



remote

Please note: If this value has been previously set using the LANTIME Web Interface, setting this value directly from the FDM module will overwrite that previous setting. In this case, if you wish to restore the old setting, this will need to be done via the LANTIME Web Interface.

### 8.6.7 Menu Entry: Time Deviation Limit

The Time Deviation limits are selected under this menu item. Whenever the Time Deviation exceeds this limit, the overflow error bit will be set (see chapter Menu Entry: Error) and the "B" LED will show red. The value is changed using the **Menu** and **Set** buttons as previously described.

TDLimit

100s

The following settings are possible:

- $\pm 10$  s
- $\pm 100$  s
- $\pm 1000$  s

When configuring these values via the LANTIME Web Interface, this value is not limited to the three values listed above and can be set to any arbitrary value. In this case, [remote] will appear on the display, as it otherwise may not be possible to display the configured value.

Line Frequency		50 Hz		
Min Frequency	49900	mHz	Max Frequency	50100
				mHz
Max Negative Time Deviation	1000000	ms	Max Positive Time Deviation	1000000
				ms

remote

Please note: If this value has been previously set using the LANTIME Web Interface, setting this value directly from the FDM module will overwrite that previous setting. In this case, if you wish to restore the old setting, this will need to be done from the LANTIME Web Interface.

### 8.6.8 Menu Entry: Analog Outputs (Analog 1 and Analog 2)

The FDM module provides two independent analog outputs, A1 and A2. These have a voltage range of -2.5 V to +2.5 V, adjustable in 65536 steps. The variation of the corresponding analog output voltage output can be configured to correlate with either the frequency deviation or with the time deviation.

A dark grey rectangular button with the text "Analog 1" in a white, monospaced font.A dark grey rectangular button with the text "Time Dev" in a white, monospaced font.A dark grey rectangular button with the text "Freq.Dev" in a white, monospaced font.

This is done in this submenu item by selecting [Time Dev] or [Freq.Dev]. The minimum/maximum value ( $\pm 2.5V$ ) is output when the selected deviation value reaches or exceeds the limits set either in the corresponding menu ([FD Limit] or [TD Limit]) or using the LANTIME Web Interface. If the maximum voltage variation is reached and the correlated value continues to rise or fall as appropriate, the relevant error bit will be set (see Menu Entry: Error) and the "A" or "B" LED will show red.

The values of the two analog outputs can also be read via the serial port COM0 by sending the character "A" (ASCII code 41h). In this case, the FDM will send a string formatted as follows:

```
A1:XXXX_A2:XXXX<CR><LF>
```

values in hex code (0000h ... FFFFh), base value is 8000h



### 8.6.9 Menu Entry: Error

The FDM module registers fault and overflow events and sets or clears eight error bits accordingly. These bits are shown under this submenu item. These bits can be read to enable the user to establish why the "In" LED is red or the "A" or "B" LEDs are lit.



Each error bit documents a certain fault type that may occur during operation. The format of the displayed bits is: X8 X7 X6 X5 X4 X3 X2 X1. The bits have the following meaning:

- X8: A2 Overflow - analog output 2 has reached its full variation
- X7: A1 Overflow - analog output 1 has reached its full variation
- X6: Time Deviation Overflow - the time deviation exceeds  $\pm 99.999$  s
- X5: Frequency Overflow - the frequency deviation exceeds  $\pm 9.999$  Hz or the frequency is  $< 45$  Hz or  $> 65$  Hz
- X4: REF Free - no Pulse-per-Second signal (PPS) from the reference
- X3: PL Free - no power line detected (PL Time not governed by Power Line Frequency)
- X2: No Time String - no time string from the reference
- X1: No PL Init - the PL Time has not been initialized (yet)

The error bits can be read via the serial port COM0 by sending the character "E" (ASCII code 45h). The return string is formatted as follows:

**ERROR:X8 X7 X6 X5 X4 X3 X2 X1<CR><LF>**

### 8.6.10 Menu Entry: Serial Number

The serial number of the FDM is displayed under this menu item. This number can often be useful to know when contacting Meinberg for support. The **Set** button is pressed to first display the first eight digits of the serial number, then pressed again to display the last four digits.

A dark rectangular LCD display showing the text "Ser.-No." in a white, monospaced font.A dark rectangular LCD display showing the text "10000990" in a white, monospaced font.A dark rectangular LCD display showing the text "0411" in a white, monospaced font.

The serial number and the firmware revision of the FDM can be read via serial output by sending the three characters "SN!" via COM0 to the module. This will return the following string (as an example):

```
SN: 041110000990 REV:01.00/01<CR><LF>
```

### 8.6.11 Menu Entry: Firmware Revision

The current firmware revision is displayed under this menu item. This information may also be useful to know when contacting Meinberg for support.

A dark rectangular LCD display showing the text "SW Rev." in a white, monospaced font.A dark rectangular LCD display showing the text "REV:1.20" in a white, monospaced font.

The serial number and the firmware revision of the FDM can be read via serial output by sending the three characters "SN!" via COM0 to the module. This will return the following string (as an example):

```
SN: 041110000990 REV:01.20<CR><LF>
```

## 8.7 Serial Output Strings

Several output strings are available with the FDM module. Selection is made in the setup menu "Str.COM0" and "Str.COM1". The format of the output strings as well as related input strings or commands are described in the following sections.

### 8.7.1 Standard FDM String

The STANDARD string is a sequence of 62 ASCII characters containing the frequency *F*, the Frequency Deviation *FD*, the REF Time, the Power Line Time *PLT* and the Time Deviation *TD*, each item separated by a space character. The string is sent out at the beginning of every new REF Time second and ends with a Carriage Return (ASCII code 0Dh) and a Line Feed (ASCII code 0Ah). The letters displayed in italics are replaced by the calculated values whereas the other characters are part of the string:

```
F:49.984_FD:-00.016_REF:15:03:30_PLT:15:03:30.378_TD:+00.378<CR><LF>
```

The meaning of the several values is described below:

<i>F:49.984</i>	The measured power line frequency with a resolution of 1 mHz
<i>FD:-00.016</i>	The frequency deviation between calculated and nominal frequency, with sign character (+/-), resolution: 1 mHz, maximum: +-09.999 Hz
<i>REF:15:03:30</i>	The reference time from the upstream clock (hours:minutes:seconds)
<i>PLT:15:03:30.378</i>	The power line time, based on the mains frequency, (hours:minutes:seconds:milliseconds) Time jumps, like changeover in daylight saving or leap seconds will not be executed by the PL time!
<i>TD:+00.378</i>	The time deviation between REF time and PL time, with sign character (+/-), resolution: 1ms, maximum: +-99.999 s

## 8.7.2 Short FDM String

The SHORT string is a sequence of 23 ASCII characters simply containing information about the Frequency Deviation FD and Time Deviation TD, separated by a space character. The string is sent out at the beginning of every new REF Time second and ends with the characters Carriage Return (ASCII code 0Dh) and Line Feed (ASCII code 0Ah). The letters displayed in italics are replaced by the calculated values, while the other characters are part of the string:

FD:-*00.016*\_TD:+*00.378*<CR><LF>

The meaning of the several values is described below:

FD:-*00.016*                    The Frequency Deviation between calculated and nominal frequency, signed value (+/-), resolution: 1 mHz, maximum: +-09.999 Hz

TD:+*00.378*                    The Time Deviation between REF Time and PL Time,, signed value (+/-), resolution: 1 ms, Maximum +-99.999 s

## 8.7.3 Time Deviation Preset String

The time deviation TD can be preset to a value between -99.999s and +99.999s. This can be done in the setup menu "Time Deviation Init" and also via the serial interface COM0. Sending the following string to the FDM causes the module to set the time deviation and the PL time is recalculated according to this new value:

TD:+*05.873*<CR><LF>

This serial method can be used to reset the time deviation back to +00.000s. This is also caused by pulling down the /Reset input (see rear VG-Edge connector pin assignment) or by a power-up reset.

**Note:** The described time deviation preset method is available via COM0, only, and notwith COM1!

### 8.7.4 TTM1 FDM String

The TTM1 string is a sequence of 71 ASCII characters containing the Frequency F, the Frequency Deviation FD, the Time Deviation TD, the Power Line Time PLT and the Reference Time REF (preceded by the three-digit day of the year), each item separated by the characters Carriage Return (ASCII code 0Dh) and Line Feed (ASCII code 0Ah). Each of the five data items is prefixed with a fixed three-digit address (020 ... 024).

The string is pre-emptive, which means that the terminating ETX character (end-of-text, ASCII code 03h) is sent at the start of each REF Time second. The letters displayed in italics are replaced with the calculated values, while the other characters are part of the string:

```
<STX> 02049.984<CR><LF>
021-0.016<CR><LF>
022+00.378<CR><LF>
02315_03_30.378<CR><LF>
024068_15_03_30_<CR><LF>
<ETX>
```

The meaning of the several values is described below:

<b>49.984</b>	The measured Power Line Frequency with a resolution of 1 mHz
<b>-0.016</b>	The Frequency Deviation between the calculated and nominal frequency, signed value (+/-), resolution: 1 mHz, maximum: +-09.999 Hz
<b>+00.378</b>	The Time Deviation between REF Time and PL Time, with sign character (+/-), resolution: 1ms, maximum: +-99.999 s
<b>15_03_30.378</b>	The Power Line Time based on the mains frequency, (hours_minutes_seconds.milliseconds) Artificial time adjustments such as Daylight Saving Time or leap second adjustments are not accounted for!
<b>068_15_03_30</b>	The Reference Time from the upstream clock, (day-of-the-year_hours_minutes_seconds)

### 8.7.5 Over Range Condition

Whenever the frequency deviation or the time deviation exceeds its allowable limit (+-9.999 Hz or +-99.999 s), an over range condition occurs. In this case the corresponding value is sent out as a sign character (+ or -) followed by 9\_ \_ \_ , where the character represents a space, e.g.: '+9 ' would follow +9.999 when incremented by 0.001. Furthermore, this condition is indicated by the Overflow LED.

### 8.7.6 Time Deviation Preset

A Time Deviation preset value in the range of -99.999 to +99.999 seconds can be set by a serial ASCII command via the serial interface COM0. Sending the following string to the FDM causes the module to set the Time Deviation and the PL time is recalculated according to this new value. All previously accumulated Time Deviation is lost.

The ASCII command to set the preset value starts with the characters "F27PS" and ends with the Carriage-Return (ASCII code 0Dh) and Line-Feed (ASCII code 0Ah). The numbers displayed in italics are replaced by the Time Deviation preset value where as the other characters are part of the string. Examples:

```
send Preset Value +10.553:
F27PS+10.553<CR><LF> (string sent to FDM)
OK<CR><LF>           (response from FDM)
```

```
send Preset Value -08.68:
F27PS-08.68<CR><LF> (string sent to FDM)
OK<CR><LF>           (response from FDM)
```

```
read out the Preset Value:
F27PS<CR><LF>         (string sent to FDM)
F27PS=-08.680<CR><LF> (response from FDM)
```

The preset value **must** be entered with the sign (+ or -), two digits as integer (01 to 99), a dot as separator (.) and two or three following decimal places. FDM returns the **OK** acknowledge and recalculates the corresponding PL time. This causes the "Fail"-LED to be switched on for a short time before normal operation is started again.

**Note:** The described Time Deviation preset method is available via COM0, only, and **not** with COM1!

### 8.7.7 TTM2 FDM String

The TTM2 string is a sequence of 30 ASCII characters containing the REF Time (with day of the year), the Time Deviation TD and the Frequency Deviation FD. The string starts with the SOH character (Start-of-Header, ASCII code 01h) at the beginning of each new REF Time second and ends with the characters Carriage Return (ASCII code 0Dh) and Line Feed (ASCII code 0Ah). The letters displayed in italics are replaced by the calculated values, while the other characters are part of the string:

`<SOH>303:15:03:30QT+00.37F-0.016<CR><LF>`

The meaning of the several values is described below:

<b>303:15:03:30</b>	The Reference Time from the upstream clock, (day of the year:hours:minutes:seconds)
<b>Q</b>	Quality indicator: space: Time Sync (GPS has locked) ?: no timesync yet (GPS fail)
<b>T+00.37</b>	The Time Deviation between REF Time and PL Time, signed value (+/-), resolution: 10 ms, maximum: +-99.99 s
<b>F-0.016</b>	The frequency deviation between calculated and nominal frequency, signed value (+/-), resolution: 1 mHz, maximum: +-4.999 Hz

### 8.7.8 Computime Extended FDM String

The Extended Computime String is a sequence of 42 ASCII characters containing the REF time (with date and day-of-the-week), the Time Deviation TD and the frequency F. The string is send out at the beginning of every new REF time second and ends with the characters Carriage-Return (ASCII code 0Dh) and Line-Feed (ASCII code 0Ah). The letters displayed in italics are replaced by the calculated values whereas the other characters are part of the string:

`T:10:03:09:02:15:03:30D:+000.378F:49.984<CR><LF>`

The meaning of the several values is described below:

<b>10:03:09:02</b>	The date of the Reference Time from the upstream clock, (year:month:day:day-of-the-week / Monday = 01, Sunday = 07)
<b>15:03:30</b>	The Reference Time from the upstream clock, (hours:minutes:seconds)
<b>+000.378</b>	The Time Deviation between REF time and PL time, with sign character (+/-), resolution: 1ms, maximum: +-99.999s (the first digit is always 0!)
<b>49.984</b>	The measured Power Line Frequency with a resolution of 1 mHz

## 9 Installation of the GPS Antenna

**WARNING!**

Do not mount the antenna without an effective fall arrester!

**Danger of death from falling!**

- Ensure that you work safely when installing antennas!
- Never work without an effective fall arrester!

**WARNING!**

Do not work on the antenna system during thunderstorms!

**Danger of death from electric shock!**

- Do not carry out any work on the antenna system or the antenna cable if there is a risk of lightning strike.
- Do not carry out any work on the antenna system if it is not possible to maintain the prescribed safe distance to exposed lines and electrical substations.

### Selecting the Antenna Location

To avoid difficulties with synchronization, select a location that allows for an unobstructed view of the sky so as to ensure that enough satellites can be found. The line of sight between the antenna and satellites should not be obstructed in any way. The antenna must also not be installed under power lines or other electrical lighting or power circuits.

**Installation Conditions for Optimum Operation:**

- clear view of 8° above the horizon or
- clear view towards equator (if clear view of 8° not possible) or
- clear view between 55th north and 55th south parallels (satellite orbits).



Problems may arise if all of these views are obstructed, as four satellites must be located to calculate a new position.



## Mounting the Antenna

1.

Use the included mounting kit to mount the antenna at a distance of 50 cm from other antennas, either on a vertical pole of a diameter of no more than 60 mm, or directly onto a wall.

The antenna cable should then be connected to the Type-N connector of the antenna.

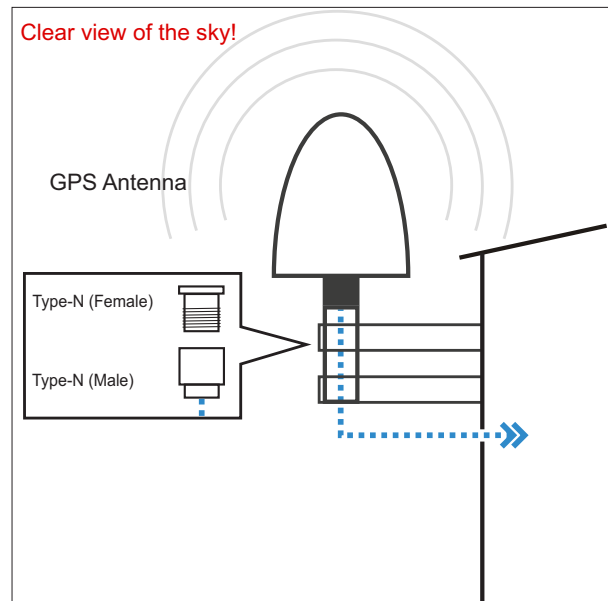

Make sure that the maximum cable length is not exceeded when installing the antenna cable between the antenna and receiver. The maximum length will depend on the type of cable used (H155, RG58) and its attenuation factor.

2.

Voltage surges (e.g., caused by lightning strike) may be transmitted along the antenna cable and cause damage to the receiver. Using a MBG S-PRO surge protector can help to protect your receiver against such surges.

If installed in a waterproof housing, the MBG S-PRO can be installed outdoors. However, Meinberg recommends installing the surge protector indoors—as closely to the entrance point of the antenna cable as possible—in order to minimize the risk of surge damage (such as that caused by lightning strike).

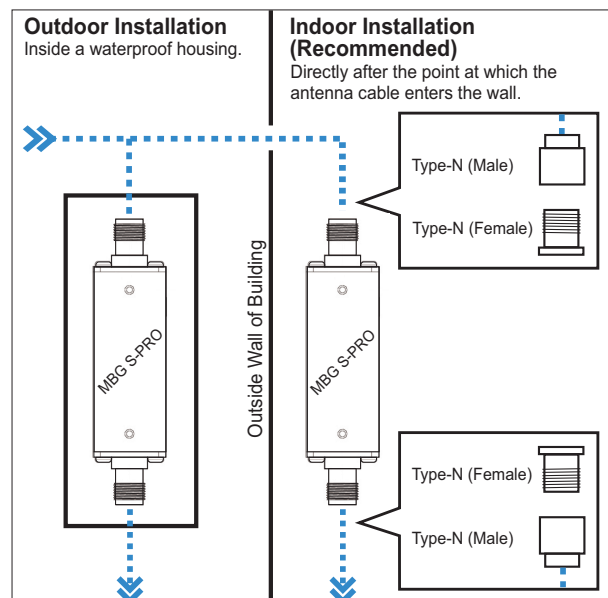

3.

To ground the antenna cable, connect the surge protector to a grounding busbar using a grounding conductor (see illustration).

Once installation is complete, connect the other end of the antenna cable to the surge protector female connector.

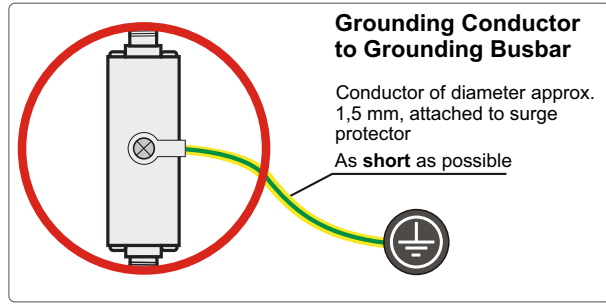

4.

The next step is to connect the supplied coaxial cable from the surge protector to the receiver.

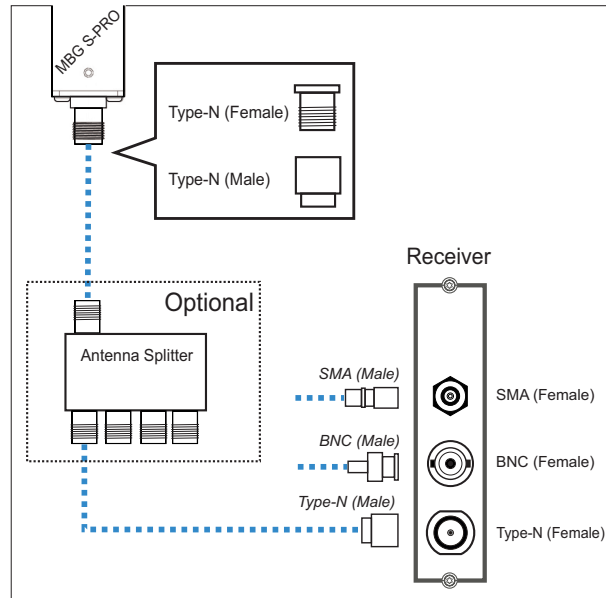

## Optional Antenna Splitter

Multiple receivers can be connected to one antenna using the antenna splitter. When doing so, be aware that the total distance, comprising the cable from the antenna to the splitter, and from there to the receiver, must not exceed the maximum cable length. The splitter may be installed at any location between the surge protector and the receivers.

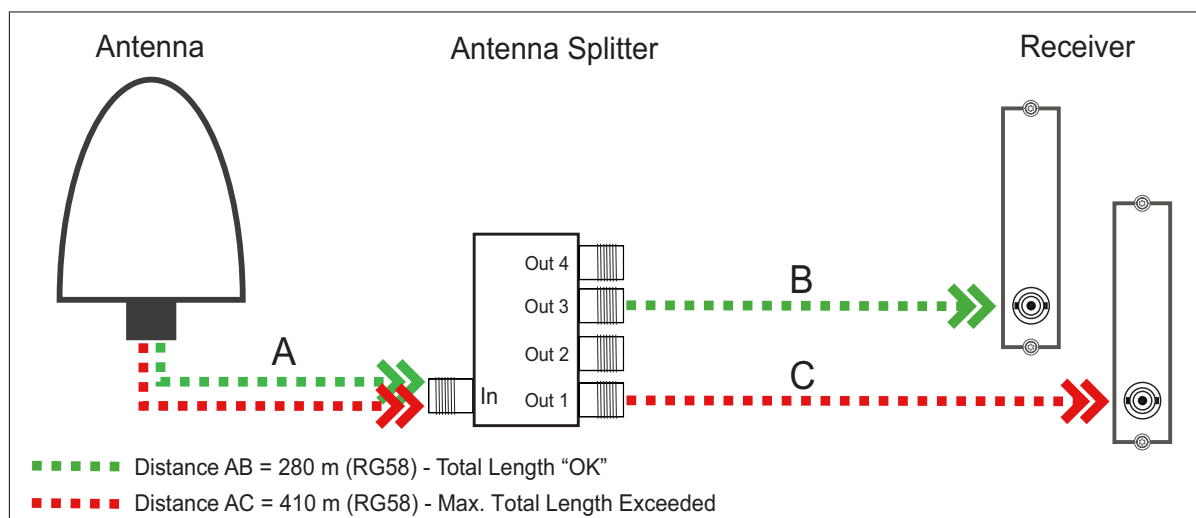

## Compensating for Signal Propagation Delay in the Antenna Cable

To enable the connected receiver to compensate for the signal propagation delay inherent in the antenna cable, you will need to enter either the length of your antenna cable in meters or the offset time in nanoseconds into your receiver.

### Antenna Cable Length (m):

The satellite signal reception is delayed as a result of coaxial cable used.

Cable	Delay	Usage
RG58U	5 ns/m	For GPS and GNS-UC receivers
H155	4 ns/m	For GNS and GNM receivers

The cable length entered (from antenna to receiver) is used by the system to calculate the delay time and to automatically compensate for propagation delay. A value of 20 m is set by default.

When using a different type of coaxial cable, please use the "By Delay" option. You will need to calculate the delay yourself using the information provided in the product specifications provided by the manufacturer of your coaxial cable.

# 10 Technical Appendix: GPS Antenna + Accessories

Physical Dimensions:

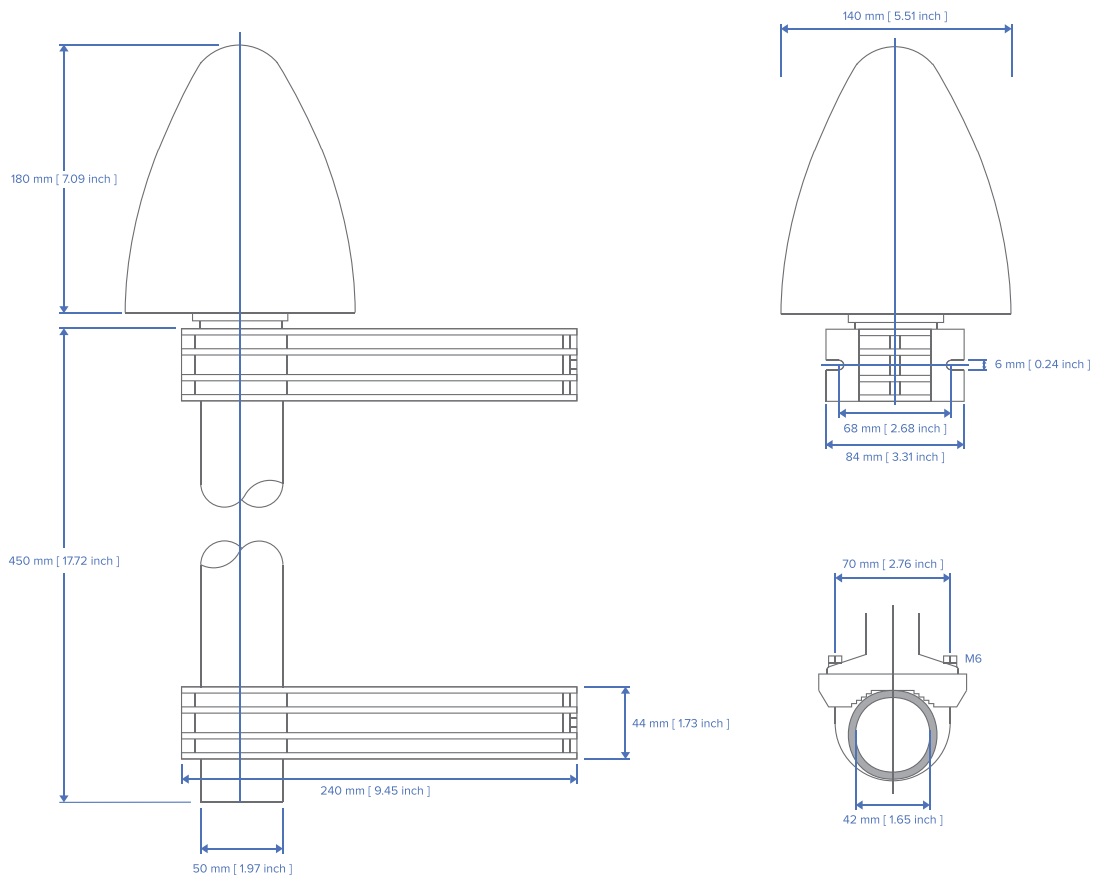

## Specifications:

Power Supply:	15 V, 100 mA (Provided via Antenna Cable)	
Reception Frequency:	1575.42 MHz	
Bandwidth:	9 MHz	
Frequencies:	Mixed Frequency	10 MHz
	IF frequency:	35.4 MHz
Connector:	Type-N Female	
Form Factor:	ABS Plastic Case for Outdoor Installation	
IP Rating:	IP66	
Humidity:	95 %	
Temperature Range:	-60 °C to +80 °C (-76 °F to 176 °F)	
Weight:	1.6 kg (3.53 lbs), Including Mounting Kit	

## 10.1 Antenna Cable

Cable Type	Cable Diameter (mm/in)	Attenuation at 100 MHz (db)/100 m/328 ft	Max. Cable Length (m/ft)	Used for Receiver Type
RG58/CU	5/0.2	17	300/984	GPS/GNS-UC/PZF
RG213	10.3/0.41	7	700/2297	GPS/GNS-UC
H155	5.4/0.21	9.1	70/230	GNM/GNS
H2010 Ultraflex	7.3/0,29	5.8	150/492	GNM/GNS

Please refer to the data sheet of the cable in question for further specifications.

## 10.2 Antenna Short Circuit



This information only applies to devices with a front display.

If the antenna line is short-circuited, the following message will be shown on the display:

```
Antenna Short-Circuit
Disconnect Power!!
```

If this message appears, the clock must be switched off and the cause of the problem must be eliminated before the clock can be switched back on. The supply voltage for the antennas/converter unit is around 15 V DC with the antenna connected.

## 10.3 Technical Specifications: MBG S-PRO Surge Protection

Adapter plug with replaceable gas discharge tube for coaxial signal connections.

Connector Type: Type-N connector female/female. The MBG S-PRO set includes a surge protector (Phoenix CN-UB-280DC-BB), a pre-assembled coaxial cable, and a mounting bracket.

The coaxial cable surge protector must be installed on the antenna line. The shielding is grounded using a conductor that is short as possible. The CN-UB-280DC-BB is equipped with two Type-N female connectors and has no dedicated input/output polarity and no preferred installation orientation.



Phoenix CN-UB-280DC-BB

### Features:

- High RF Performance
- Multiple Strike Capability
- 20 kA Surge Protection
- Bidirectional Protection

<b>Installation Method:</b>	Connector Type-Specific Adapter Plug	
<b>Direction of Action:</b>	Line Shield/Earth Ground	
<b>Maximum Continuous Operating Voltage:</b>	UC (Wire-Ground) 195 V AC	280 V DC
<b>Rated Current:</b>	$I_N$	5 A (25 °C)
<b>Effective Operating Current:</b>	$I_C$ at UC	$\leq 1 \mu\text{A}$
<b>Rated Discharge Current:</b>	$I_n$ (8/20) $\mu\text{s}$ (Core-Earth) $I_n$ (8/20) $\mu\text{s}$ (Core-Shield)	20 kA 20 kA
<b>Total Surge Current:</b>	(8/20) $\mu\text{s}$ (10/350) $\mu\text{s}$	20 kA 2.5 kA

<b>Max. Discharge Current:</b>	$I_{\max}$ (8/20) $\mu$ s Maximum (Core-Shield)	20 kA
<b>Rated Pulse Current:</b>	$I_{\text{an}}$ (10/1000) $\mu$ s (Core-Shield)	100 A
<b>Impulse Discharge Current:</b>	(10/350) $\mu$ s, Peak Value $I_{\text{imp}}$	2.5 kA
<b>Output Voltage Limit:</b>	At 1 kV/ $\mu$ s (Core-Earth) spike At 1 kV/ $\mu$ s (Core-Earth) spike	$\leq$ 900 V $\leq$ 900 V
<b>Response Time:</b>	tA (Core-Earth) tA (Core-GND)	$\leq$ 100 ns $\leq$ 100 ns
<b>Input Attenuation:</b>	aE, asym.	Typically 0.1 dB ( $\leq$ 1.2 GHz) Typically 0.2 dB ( $\leq$ 2.2 GHz)
<b>Cut-Off Frequency:</b>	$f_g$ (3 dB), asym. (Shield) in 50 $\Omega$ System	$>$ 3 GHz
<b>Standing Wave Ratio:</b>	VSWR in a 50 $\Omega$ System	Typically 1.1 ( $\leq$ 2 GHz)
<b>Permissible HF Power:</b>	$P_{\max}$ at VSWR = xx (50 $\Omega$ System)	700 W (VSWR = 1.1) 200 W (VSWR = $\infty$ )
<b>Capacitance:</b>	(Core-Earth) Asymmetric (Shield)	Typically 1.5 pF Typically 1.5 pF
<b>Surge Current Resistance:</b>	(Core-Earth)	C1 - 1 kV/500 A C2 - 10 kV/5 kA C3 - 100 A D1 - 2.5 kA
<b>Ambient Temperature:</b>	(During Operation)	-40 °C ... 80 °C
<b>Supported Altitude:</b>		$\leq$ 2000 m (above sea level)
<b>IP Rating:</b>		IP55
<b>Housing Material:</b>		Nickel-Plated Brass Colored Nickel
<b>Dimensions:</b>		Height 25 mm, Width 25 mm, Depth 67 mm
<b>Connection Type:</b>	IN OUT	Type-N Connector 50 $\Omega$ Type-N Connector, Female Type-N Connector, Female
<b>Standards/Regulations:</b>		IEC 61643-21 2000 + A1:2008 EN 61643-21 2001 + A1:2009

The original product page of the supplier (see link) of the CN-UB-280DC-BB surge protector is the source of the specifications above. Please refer to the manufacturer's product page at the following link for detailed specifications as well as a variety of product-specific documents:

<https://www.phoenixcontact.com/online/portal/gb/?uri=pxc-oc-itemdetail:pid=2818850>



### 10.3.1 MBG S-PRO: Physical Dimensions

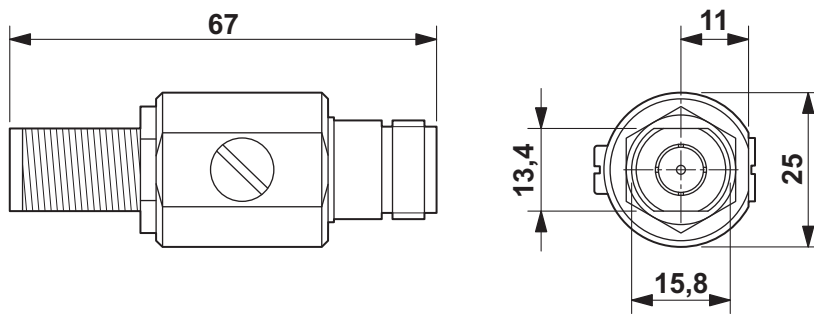

### 10.3.2 Installation and Grounding

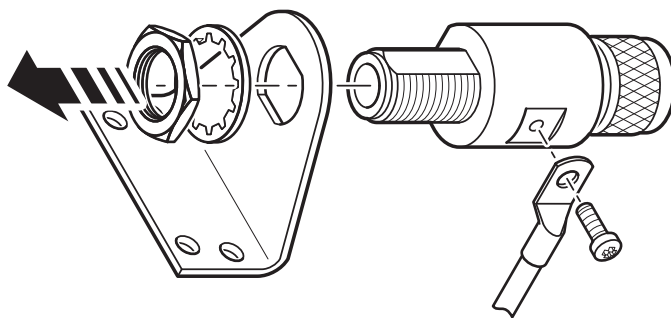

# 11 RoHS and WEEE

## Compliance with EU Directive 2011/65/EU (RoHS)

We hereby declare that this product is compliant with the European Union Directive 2011/65/EU and its delegated directive 2015/863/EU "Restrictions of Hazardous Substances in Electrical and Electronic Equipment". We ensure that electrical and electronic products sold in the EU do not contain lead, cadmium, mercury, hexavalent chromium, polybrominated biphenyls (PBBs), polybrominated diphenyl ethers (PBDEs), bis(2-ethylhexyl)phthalat (DEHP), benzyl butyl phthalate (BBP), dibutyl phthalate (DBP), or diisobutyl phthalate (DIBP) above the legal limits.



## WEEE status of the product

This product is handled as a B2B (Business to Business) category product. To ensure that the product is disposed of in a WEEE-compliant fashion, it must be returned to the manufacturer. Any transportation expenses for returning this product (at end-of-life) must be covered by the end user, while Meinberg will bear the costs for the waste disposal itself.



# 12 Declaration of Conformity

## Konformitätserklärung

Doc ID: LANTIME M900/GPS/FDM-D/BGT-September 24, 2021

**Hersteller**  
*Manufacturer*                      Meinberg Funkuhren GmbH & Co. KG  
Lange Wand 9, D-31812 Bad Pyrmont

erklärt in alleiniger Verantwortung, dass das Produkt,  
*declares under its sole responsibility, that the product*

**Produktbezeichnung**  
*Product Designation*              LANTIME M900/GPS/FDM-D/BGT

auf das sich diese Erklärung bezieht, mit den folgenden Normen und Richtlinien übereinstimmt:  
*to which this declaration relates is in conformity with the following standards and provisions of the directives:*

---

RED – Richtlinie                      ETSI EN 303 413 V1.1.1 (2017-06)  
*RED Directive*

2014/53/EU

---

EMV – Richtlinie                      ETSI EN 301 489-1 V2.2.3 (2019-11)  
*EMC Directive*                      ETSI EN 301 489-19 V2.1.1 (2019-04)

2014/30/EU

DIN EN 61000-6-2:2019  
DIN EN 61000-6-3:2007 + A1:2011  
DIN EN 55032:2015  
DIN EN 55024:2010 + A1:2015  
DIN EN 61000-3-2:2019  
DIN EN 61000-3-3:2013 + A1:2019

---

Niederspannungsrichtlinie              DIN EN 62368-1:2014 + A11:2017  
*Low-voltage Directive*

2014/35/EU

---

RoHS – Richtlinie                      DIN EN IEC 63000:2018  
*RoHS Directive*

2011/65/EU + 2015/863/EU

---

Bad Pyrmont, September 24, 2021

  
Stephan Meinberg  
Production Manager