



MANUAL

RD/GPS

FS-8/PS-8/RPS/MP

Redundant GPS Receiver System

17th September 2018

Meinberg Funkuhren GmbH & Co. KG

Front view (Frontansicht) RD/GPS

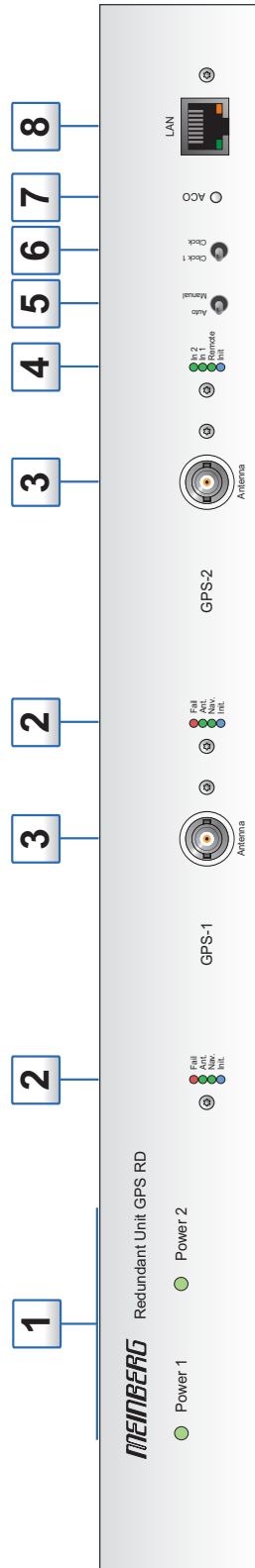

ENGLISH

1. Power supply Status-LEDs (Power 1 / Power 2)
2. GPS 1 / 2 Status-LEDs
3. GPS Antenna 1 / 2, BNC
4. Status-LEDs In1 (Clock 1) / In2 (Clock 2) / Remote / Init
5. Changeover switch "Clk 1 / Clk 2", "Auto / Man"
6. Changeover switch "Clk 1 / Clk 2"
7. ACO Button (Access Control Override)
8. Network connector "Remote Control", RJ45

DEUTSCH

1. Netzteil Status-LEDs (Power 1 / Power 2)
2. GPS 1 / 2 Status-LEDs
3. GPS Antenne 1 / 2, BNC
4. Status-LEDs Clock 1 / Clock 2 / Remote / Init
5. Umschalter "Clk 1 / Clk 2", "Auto / Man"
6. Umschalter "Clk 1 / Clk 2"
7. ACO Button (Access Control Override)
8. Netzwerk Anschluss "Remote Control", RJ45

Rear view (Rückansicht) RD/GPS

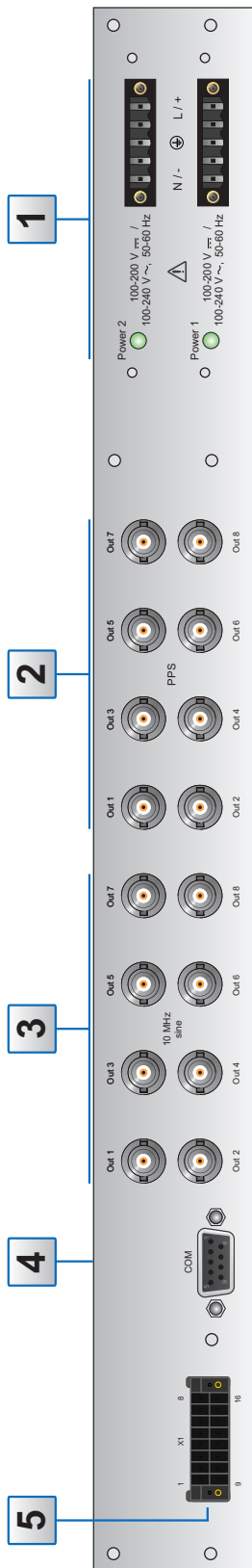

ENGLISH

1. Power supply connector
2. PPS outputs, BNC
3. 10 MHz sine outputs, BNC
4. Serial port COM 0, 9pin D-Sub female
5. Error Relay and Time-Status outputs, DMC-X1 connector

DEUTSCH

1. Spannungsversorgung
2. PPS Ausgänge, BNC
3. 10 MHz Sinus Ausgänge, BNC
4. Serielle Schnittstelle COM 0, 9pol D-Sub Buchse
5. Error Relais und Time-Status Ausgänge, DMC-X1 Stecker

Table of Contents

1	Imprint	1
2	Important Safety Information	2
2.1	Important Safety Instructions and Protective Measures	2
2.2	Used Symbols	3
2.3	Security during Installation	5
2.4	Safety during Operation	8
2.5	Safety during Maintenance	9
2.6	Handling Batteries	9
2.7	Cleaning and Care	10
2.8	Prevention of ESD Damage	10
2.9	Return of Electrical and Electronic Equipment	11
2.10	Protective Conductor-/ Ground-Terminal RD-GPS	12
3	General Information GPS	13
4	The Modular System RD-GPS	14
4.1	GPS180 Features	14
4.2	Time Zone and Daylight Saving	14
4.3	Pulse and Frequency Outputs	14
4.4	Asynchronous Serial Ports	14
5	Installation	16
5.1	Mounting the GPS Antenna	16
5.1.1	Example:	17
5.1.2	Antenna Assembly with Surge Voltage Protection	18
5.2	Powering Up the System	19
5.3	Quick Start Guide for Initial Operation	20
6	The Front Panel Layout	24
6.1	Power LED	25
6.2	GPS Receiver - Status LEDs	25
6.3	GPS Antenna	26
6.4	Status LEDs Switch Unit	27
6.5	10/100base-T Ethernet (IEEE 803.2).	28
7	RSC-XPT	29
8	Rear connectors	30
8.1	Power Connector	31
8.2	Pulse Per Second Output	32
8.3	10 MHz sine Output	32
8.4	RS232 COMx Timestring	33
8.5	DMC X1 Connector	34
9	Firmware Updates	35
10	Technical Specifications GPS receiver	36
10.1	Oscillator specifications	37
10.2	Technical Specifications GPS Antenna	38
10.3	Time Strings	39
10.3.1	Format of the Meinberg Standard Time String	39
10.3.2	Format of the Meinberg GPS Time String	40
10.3.3	Format of the Meinberg Capture String	41

10.3.4	Format of the SAT Time String	42
10.3.5	Format of the Uni Erlangen String (NTP)	43
10.3.6	Format of the NMEA 0183 String (RMC)	45
10.3.7	Format of the NMEA 0183 String (GGA)	46
10.3.8	Format of the NMEA 0183 String (ZDA)	47
10.3.9	Format of the ABB SPA Time String	48
10.3.10	Format of the Computime Time String	49
10.3.11	Format of the RACAL standard Time String	50
10.3.12	Format of the SYSPLEX-1 Time String	51
10.3.13	Format of the ION Time String	52

11 Declaration of Conformity **53**

1 Imprint

Meinberg Funkuhren GmbH & Co. KG
Lange Wand 9, 31812 Bad Pyrmont / Germany

Phone: + 49 (0) 52 81 / 93 09 - 0

Fax: + 49 (0) 52 81 / 93 09 - 230

Internet: <https://www.meinbergglobal.com>

Mail: info@meinberg.de

Date: 2018-06-18

2 Important Safety Information

2.1 Important Safety Instructions and Protective Measures

The following safety instructions must be respected in all operating and installation phases of the device. Non-observance of safety instructions, or rather special warnings and operating instructions in product manuals, violates safety standards, manufacturer instructions and proper usage of the device. Meinberg Funkuhren shall not be responsible for any damage arising due to non-observance of these regulations.



Depending on your device or the installed options some information is not valid for your device.



The device satisfies the requirements of the following EU regulations: EMC-Directive, Low Voltage Directive, RoHS Directive and - if applicable - the Radio Equipment Directive.

If a procedure is marked with the following signal words, you may only continue, if you have understood and fulfilled all requirements. In this documentation dangers and indications are classified and illustrated as follows:



DANGER!

The signal word indicates an imminently hazardous situation with a high risk level . This notice draws attention to an operating procedure or similar proceedings, of which a non-observance may result in serious personal injury or death .



WARNING!

The signal word indicates a hazard with a medium risk gradient . This notice draws attention to an operating procedure, a procedure or the like which, if not followed, can lead to serious injuries , possibly resulting in death .



CAUTION!

The signal word indicates a hazard with a low risk gradient . This notice draws attention to an operating procedure, a procedure or the like which, if not followed, can lead to minor injuries .















ATTENTION!

This notice draws attention to an operating procedure, a procedure or the like which, if not followed, can cause damage to the product or loss of important data .

2.2 Used Symbols

The following symbols and pictograms are used in this manual. To illustrate the source of danger, pictograms are used, which can occur in all hazard classes.

Symbol	Beschreibung / Description
	IEC 60417-5031 Gleichstrom / <i>Direct current</i>
	IEC 60417-5032 Wechselstrom / <i>Alternating current</i>
	IEC 60417-5017 Erdungsanschluss / <i>Earth (ground) terminal</i>
	IEC 60417-5019 Schutzleiteranschluss / <i>Protective earth (ground) terminal</i>
	ISO 7000-0434A Vorsicht / <i>Caution</i>
	IEC 60417-6042 Vorsicht, Risiko eines elektrischen Schlages / <i>Caution, risk of electric shock</i>
	IEC 60417-5041 Vorsicht, heiße Oberfläche / <i>Caution, hot surface</i>
	IEC 60417-6056 Vorsicht, Gefährlich sich bewegende Teile / <i>Caution, moving fan blades</i>
	IEC 60417-6172 Trennen Sie alle Netzstecker / <i>Disconnection, all power plugs</i>
	IEC 60417-5134 Elektrostatisch gefährdete Bauteile / <i>Electrostatic Sensitive Devices</i>
	IEC 60417-6222 Information generell / <i>Information general</i>
	ISO 7000-1329 Laserstrahl / <i>Laser beam</i>
	2012/19/EU Dieses Produkt fällt unter die B2B Kategorie. Zur Entsorgung muss es an den Hersteller übergeben werden. <i>This product is handled as a B2B category product. In order to secure a WEEE compliant waste disposal it has to be returned to the manufacturer.</i>

The manuals for a product are included in the scope of delivery of the device on a USB stick. The manuals can also be obtained via the Internet. Enter www.meinbergglobal.com into your browser, then enter the corresponding device name in the search field at the top.



This manual contains important safety instructions for the installation and operation of the device. Please read this manual completely before using the unit.

This device may only be used for the purpose described in this manual. In particular, the given limits of the device must be observed. The safety of the installation in which the unit is integrated is the responsibility of the installer!

Non-observance of these instructions can lead to a reduction in the safety of this device!

Please keep this manual in a safe place.

This manual is intended exclusively for electricians or persons trained by an electrician who are familiar with the applicable national standards and safety rules. Installation, commissioning and operation of this device may only be carried out by qualified personnel.



Depending on your device or the installed options, some information for your device may be invalid.

2.3 Security during Installation



Preparing for Commissioning

This built-in unit, has been designed and examined according to the requirements of the standard IEC 60950-1 „Information Technology Equipment - Safety“.

When the built-in unit is used in a terminal (e.g., housing cabinet), additional requirements according to Standard IEC 60950-1 must be observed and complied with. In particular, the general requirements and the safety of electrical equipment (such as IEC, VDE, DIN, ANSI) as well as the applicable national standards are to be observed.

The device has been developed for use in the industrial sector as well as in residential areas and can only be used in such environments. For environments with higher levels of soiling, additional measures, e.g. Installation in an air-conditioned control cabinet required.

Transport, Unpacking, Installation

If the unit is brought into the operating room from a cold environment, condensation may occur, wait until the unit is temperature-controlled and absolutely dry before operating it.

When unpacking, setting up, and before operating the equipment, be sure to read the information on the hardware installation and the specifications of the equipment. These include, for example, dimensions, electrical characteristics, and necessary ambient and climatic conditions, etc.

The fire protection must be ensured in the installed state.

For mounting, the housing must not be damaged. No holes may be drilled in the housing.

For safety reasons, the device with the highest mass should be installed in the lowest position of the rack. Other devices must be placed from the bottom to the top.

The device must be protected against mechanical stress such as vibration or shock.



Connecting Data Cables

During a thunderstorm, data transmission lines must not be connected or disconnected (risk of lightning).

When wiring the devices, the cables must be connected or disconnected in the order of the arrangement described in the user documentation accompanying the device. Always attach all cables to the plug during connection and removal. Never pull the cable itself. Pulling the cable can cause the cables to disconnect from the plug.

Install the cables in way that they do not constitute a hazard (danger of tripping) and are not damaged, i.e. kinked.

Connecting Power Supply

This equipment is operated at a hazardous voltage. Non-observance of the safety instructions in this manual may result in serious personal injury or property damage.

Before connecting to the power supply, a grounding cable must be connected to the earth connection of the device.

Before operation, check that all cables and lines work properly and are undamaged. Pay particular attention to the facts that the cables do not have kinks or that they are not too short around corners, and no objects are placed on the cables. Also make sure that all connections are secure. Faulty shielding or cabling will endanger your health (electrical shock) and may destroy other equipment.

Ensure that all necessary safety precautions have been taken. Make all connections to a unit before turning on the power. Observe the safety instructions on the device (see safety symbols).

The metal housing of the device is grounded. It must be ensured that enough air and creepage distances to neighboring voltage-carrying parts are provided during assembly in the control cabinet and no short circuits are caused.

In the case of malfunctions or servicing (e.g. in the event of a damaged housing or power cable or when fluids or foreign objects enter), the current flow can be interrupted. Questions about the house installation, need to be clarified with your house administration.

The power supply should be connected with a short, low-inductance line.

AC Power Supply	DC Power Supply
<ul style="list-style-type: none"> • The device is a device of protection class 1 and may only be connected to a grounded outlet (TN system). • For safe operation, the device must be protected by an installation fuse of max. 16 A and equipped with a residual current circuit breaker in accordance with the applicable national standards. • The unit must always be disconnected from the mains and not from the appliance. • Devices with mains plugs are equipped with a safety-tested mains cable of the country of use and may only be connected to a grounded shockproof socket, otherwise electric shock may occur. • Make sure that the mains socket on the appliance or the mains socket of the house installation is freely accessible to the user so that the mains cable can be pulled out of the socket in case of emergency. 	<ul style="list-style-type: none"> • Outside the assembly group the device must be disconnectable from the power supply in accordance with the provisions of IEC 60950-1 (e.g. by the primary line protection). • Installation and disassembly of the power supply plug is only permitted if the assembly group is switched off (e.g. by the primary line protection). • The supply lines must be adequately secured and dimensioned. <p style="text-align: center;"><i>Connection Cross Section:</i> $1\text{ mm}^2 - 2.5\text{ mm}^2$ 17 AWG – 13 AWG</p> <ul style="list-style-type: none"> • The device must be supplied with a suitable disconnecter (switch). The separation device must be easily accessible, placed near the device and marked as a separation device for the unit.

AC Power Supply

- This device is a device of "Protection Class 1" and may only be connected to a grounded socket (TN system).
- For safe operation, the device must be protected by an installation fuse of max. 16 A and equipped with a residual current circuit breaker in accordance with the applicable national standards.
- The unit must always be disconnected from mains first and not from the appliance.
- Devices with mains plugs are equipped with a safety-tested mains cable of the country it is deployed in and may only be connected to a properly grounded earthing contact socket, otherwise electric shock is expected.
- Ensure that the socket on the appliance or the mains socket of the house installation is freely accessible to the user, so that the mains cable can be pulled out of the socket in case of emergency.

DC Power Supply

- In accordance with the provisions of IEC 60950-1 the device must be disconnectable outside the system (e.g. by the primary line protection).
- Installation and disassembly of the voltage supply plug is only permitted when the module is switched off (e.g. by the primary line protection).
- The supply lines must be adequately protected and dimensioned.
- Supply of the device must be carried out via a suitable disconnecting device (switch). The disconnecting device must be easily accessible, placed near the system and marked as a disconnecting device.

2.4 Safety during Operation



WARNING!

Avoiding Short-Circuits

Make sure not to get any objects or liquids inside the unit. Electric shock or short circuit could result.

Ventilation Slots

Make sure that the ventilation slots are not covered or dusty, as there is a danger of overheating during operation. Disturbances during operation can result.

Normal Operation

The normal operation and the observance of the EMC limits (electromagnetic compatibility) are only ensured if the housing cover is properly installed and when the doors are closed (cooling, fire protection, shielding against electrical, magnetic and electromagnetic fields).



Switch off in fault / service case

By switching off, the devices are not disconnected from the power supply. In the event of a fault or service case, the devices must be immediately disconnected from all power supplies.

Follow the steps below:

- Switch off the device
- Disconnect all power plugs
- Inform the service
- Devices that are connected via one or more uninterruptible power supplies (UPS) remain operational even when the UPS power cord is disconnected. Therefore, you must put the UPS out of operation according to the documentation of the corresponding user documentation.

2.5 Safety during Maintenance



WARNING!

When you are expanding the device, use only device parts that are approved for the system. Non-observance may result in injury to the EMC or safety standards and cause malfunction of the device.

If device parts, which are released for the system, are extended or removed there may be a risk of injury in the area of the hands, due to the pull-out forces (approx. 60 N).

The service informs you which device parts may be installed.

The device must not be opened, repairs to the device may only be carried out by the manufacturer or by authorized personnel. Improper repairs can result in considerable danger to the user (electric shock, fire hazard).

Unauthorized opening of the device or of individual parts of the device can also lead to considerable risks for the user and result in a loss of warranty as well as an exclusion of liability.



- Danger due to moving parts - keep away from moving parts.



- Device parts can become very hot during operation. Do not touch these surfaces! If necessary, switch off the unit before installing or removing any equipment, and allow it to cool down.

2.6 Handling Batteries



CAUTION!

The lithium battery on the receiver modules has a service life of at least 10 years. If an exchange is necessary, the following notes must be observed:

The device is equipped with a lithium battery. The battery must not be short-circuited or recharged. Replacement of the lithium battery may only be carried out by the manufacturer or authorized personnel.

Risk of explosion if the battery is not replaced correctly. Replace only with the same or equivalent type recommended by the manufacturer.

When disposing used batteries, observe the local regulations for the disposal of hazardous waste.

2.7 Cleaning and Care



ATTENTION!

Do not wet clean the appliance! Penetrating water can cause considerable dangers to the user (e.g., electric shock).

Liquid can destroy the electronics of the device! Liquid penetrates into the housing of the device and can cause a short circuit of the electronics.

Only clean with a soft, dry cloth. Never use solvents or cleaners.

2.8 Prevention of ESD Damage



ATTENTION!

The designation ESD (Electrostatic Sensitive Devices) refers to measures which are used to protect electrostatically endangered components from electrostatic discharge and thus to prevent destruction. Systems and assemblies with electrostatically endangered components usually have the following characteristics:



Indicator for assemblies with electrostatic endangered components

The following measures protect electrostatically endangered components from destruction:

Prepare removal and installation of assemblies

Unload yourself (for example, by touching a grounded object) before touching assemblies.

Ensure that you wear a grounding strap on the wrist when working with such assemblies, which you attach to an unpainted, non-conductive metal part of the system.

Use only tools and devices that are free from static electricity.

Transporting Assemblies

Assemblies may only be touched at the edge. Do not touch any pins or conductors on assemblies.

Installing and Removing Assemblies

Do not touch persons who are not grounded while removing or installing components. This could result in a loss of grounding protection from your electrostatic discharge.

Storing Assemblies

Always keep assemblies in ESD protective covers. These protective covers must be undamaged. ESD protective covers, which are extremely wrinkled or even have holes, no longer protect against electrostatic discharge.

ESD protective covers must not be low-resistance and metallically conductive if a lithium battery is installed on the assembly.

2.9 Return of Electrical and Electronic Equipment



ATTENTION!

WEEE Directive on Waste Electrical and Electronic Equipment 2012/19 / EU
(WEEE Waste Electrical and Electronic Equipment)

Separate Collection

Product Category: According to the device types listed in the WEEE Directive, Appendix 1, this product is classified as an IT and communication device.



This product meets the labeling requirements of the WEEE Directive. The product symbol on the left indicates that this electronic product must not be disposed of in domestic waste.

Return and Collection Systems

For returning your old equipment, please use the country-specific return and collection systems available to you or contact Meinberg.

The withdrawal may be refused in the case of waste equipment which presents a risk to human health or safety due to contamination during use.

Return of used Batteries

Batteries marked with one of the following symbols may not be disposed of together with the household waste according to the EU Directive.

2.10 Protective Conductor-/ Ground-Terminal RD-GPS



ATTENTION!



In order to ensure safe operation and to meet the requirements of IEC 60950-1, the device must be correctly connected to the protective earth conductor via the protective earth connection terminal.



If an external earth connection is provided on the housing, it must be connected to the equipotential bonding rail (grounding rail). The mounting parts (without cable) are included in the scope of delivery.

Note:

Please use a grounding cable $\geq 1,5\text{mm}^2$
Always pay attention to a correct crimp connection!

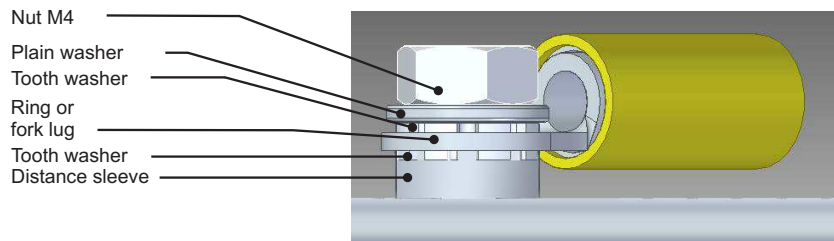

3 General Information GPS

The satellite receiver clock GPS180 has been designed to provide extremely precise time to its user. The clock has been developed for applications where conventional radio controlled clocks can't meet the growing requirements in precision. High precision available 24 hours a day around the whole world is the main feature of this system which receives its information from the satellites of the Global Positioning System.

The Global Positioning System (GPS) is a satellite-based radio-positioning, navigation, and time-transfer system. It was installed by the United States Department of Defense and provides two levels of accuracy: The Standard Positioning Service (SPS) and the Precise Positioning Service (PPS). While PPS is encrypted and only available for authorized (military) users, SPS has been made available to the general public.

GPS is based on accurately measuring the propagation time of signals transmitted from satellites to the user's receiver. A nominal constellation of 24 satellites together with several active spares in six orbital planes 20000 km over ground provides a minimum of four satellites to be in view 24 hours a day at every point of the globe. Four satellites need to be received simultaneously if both receiver position (x, y, z) and receiver clock offset from GPS system time must be computed. All the satellites are monitored by control stations which determine the exact orbit parameters as well as the clock offset of the satellites' on-board atomic clocks. These parameters are uploaded to the satellites and become part of a navigation message which is retransmitted by the satellites in order to pass that information to the user's receiver.

The high precision orbit parameters of a satellite are called ephemeris parameters whereas a reduced precision subset of the ephemeris parameters is called a satellite's almanac. While ephemeris parameters must be evaluated to compute the receiver's position and clock offset, almanac parameters are used to check which satellites are in view from a given receiver position at a given time. Each satellite transmits its own set of ephemeris parameters and almanac parameters of all existing satellites.

4 The Modular System RD-GPS

RD-GPS is a set of equipment composed of two GPS satellite controlled clocks, an RSC switch-unit and two power supply units, all installed in a metal desktop case (MULTIPAC) and ready to operate. The interface and input/output signals provided by RD-GPS are accessible via connectors in the rear and the front panel of the case. Details of the components are described below.

4.1 GPS180 Features

The hardware of GPS180 is a 100 mm x 160 mm microprocessor board. The front panel integrates 4 LED indicators and 4 push buttons. The receiver is connected to the antenna/converter unit by a 50 ohm coaxial cable (refer to "Mounting the Antenna"). Feeding the antenna/converter occurs DC insulated via the antenna cable. Optional an antenna splitter for up to four receivers connected to one antenna is available.

The navigation message coming in from the satellites is decoded by the microprocessor of the GPS180 in order to track the GPS system time. Compensation of the RF signals propagation delay is done by automatical determination of the receivers position on the globe. A correction value computed from the satellites navigation messages increases the accuracy of the boards oven controlled master oscillator (OCXO) and automatically compensates the aging of the OCXO. The last recent value is restored from the battery buffered memory at power-up.

The hardware and software configuration of the clock can be done with the help of the program, MEINBERG Device Manager.

4.2 Time Zone and Daylight Saving

GPS system time differs from the universal time scale (UTC) by the number of leap seconds which have been inserted into the UTC time scale since GPS was initiated in 1980. The current number of leap seconds is part of the navigation message supplied by the satellites, so the internal real time of the GPS180 is based on UTC time scale. Conversion to local time and annual daylight saving time can be done by the receiver's microprocessor if the corresponding parameters are set up by the user.

4.3 Pulse and Frequency Outputs

The pulse generator of the satellite radio clock RD-GPS generates pulses for the second change (P_SEC). In addition, fixed output frequencies of 10 MHz are derived from the OCXO. These signals are led out with TTL level or as sine-signal on the back connector.

By default, pulse and frequency outputs are active after the system is switched on. However, the system can be configured in the output settings (mbgdevman) of the respective Reference Clock so that these outputs only become active after the receiver decodes the incoming signals and has checked and corrected its on-board clock.

4.4 Asynchronous Serial Ports

A asynchronous serial RS232 interface are available to the user. In the default mode of operation, the serial output are disabled until the receiver has synchronized after power-up. However, the system can be configured to enable those outputs immediately after power-up. Transmission speeds, framings and mode of operation can be configured separately using Meinberg's monitoring and management software.

COM 1 is compatible with other radio remote clocks manufactured by Meinberg. It sends the time string either once per second, once per minute or on request (after receiving a "?" character). The format of the output

strings is ASCII, see the technical specifications at the end of this document for details. You can update the firmware of GPS180 also via the serial port COM 1. This port doesn't provide a serial time string.

5 Installation

5.1 Mounting the GPS Antenna

The GPS satellites are not stationary, but circle round the globe with a period of about 12 hours. They can only be received if no building is in the line-of-sight from the antenna to the satellite, so the antenna/downconverter unit must be installed in a location that has as clear a view of the sky as possible. The best reception is achieved when the antenna has a free view of 8° angular elevation above the horizon. If this is not possible, the antenna should be installed with the clearest free view to the equator, because the satellite orbits are located between latitudes 55° North and 55° South. If this is not possible, you may experience difficulty receiving the four satellites necessary to complete the receiver's position solution.

The antenna/converter unit can be mounted on a wall, or on a pole up to 60 mm in diameter. A 45 cm plastic tube, two wall-mount brackets, and clamps for pole mounting are included with every GPS180. A standard RG58 coaxial cable should be used to connect the antenna/downconverter unit to the receiver. The maximum length of cable between antenna and receiver depends on the attenuation factor of the coaxial cable.

Up to four GPS180 receivers can be run with one antenna/downconverter unit by using an optional antenna splitter. The total length of an antenna line from antenna to receiver must not be longer than the max. length shown in the table below. The position of the splitter in the antenna line does not matter.

High voltage protectors must be installed directly after reaching the indoors. The optional delivered protection kit is not for outdoor usage.

**WARNING!**

Antenna mounting without effective anti-fall protection

Danger to life due to fall!

- Pay attention to effective working safety when installing antennas!
- Never work without an effective anti-fall equipment!

**WARNING!**

Working on the antenna system during thunderstorms

Danger to life due to electrical shock!

- Do not carry out any work on the antenna system or the antenna cable if there is a risk of a lightning strike.
- Do not carry out any work on the antenna system if the safety distance to free lines and sequential circuits is exceeded.



5.1.1 Example:

Type of cable	diameter Ø [mm]	Attenuation at 100MHz [dB]/100m	max lenght. [m]
RG58/CU	5mm	17	300 ⁽¹⁾
RG213	10.5mm	7	700 ⁽¹⁾

(1) This specifications are made for antenna/converter units produced after January, 2005
The values are typically ones; the exact ones are to find out from the data sheet of the used cable

5.1.2 Antenna Assembly with Surge Voltage Protection

Optional a surge voltage protector for coaxial lines is available. The shield has to be connected to earth as short as possible by using the included mounting bracket. Normally you connect the antenna converter directly with the antenna cable to the system.

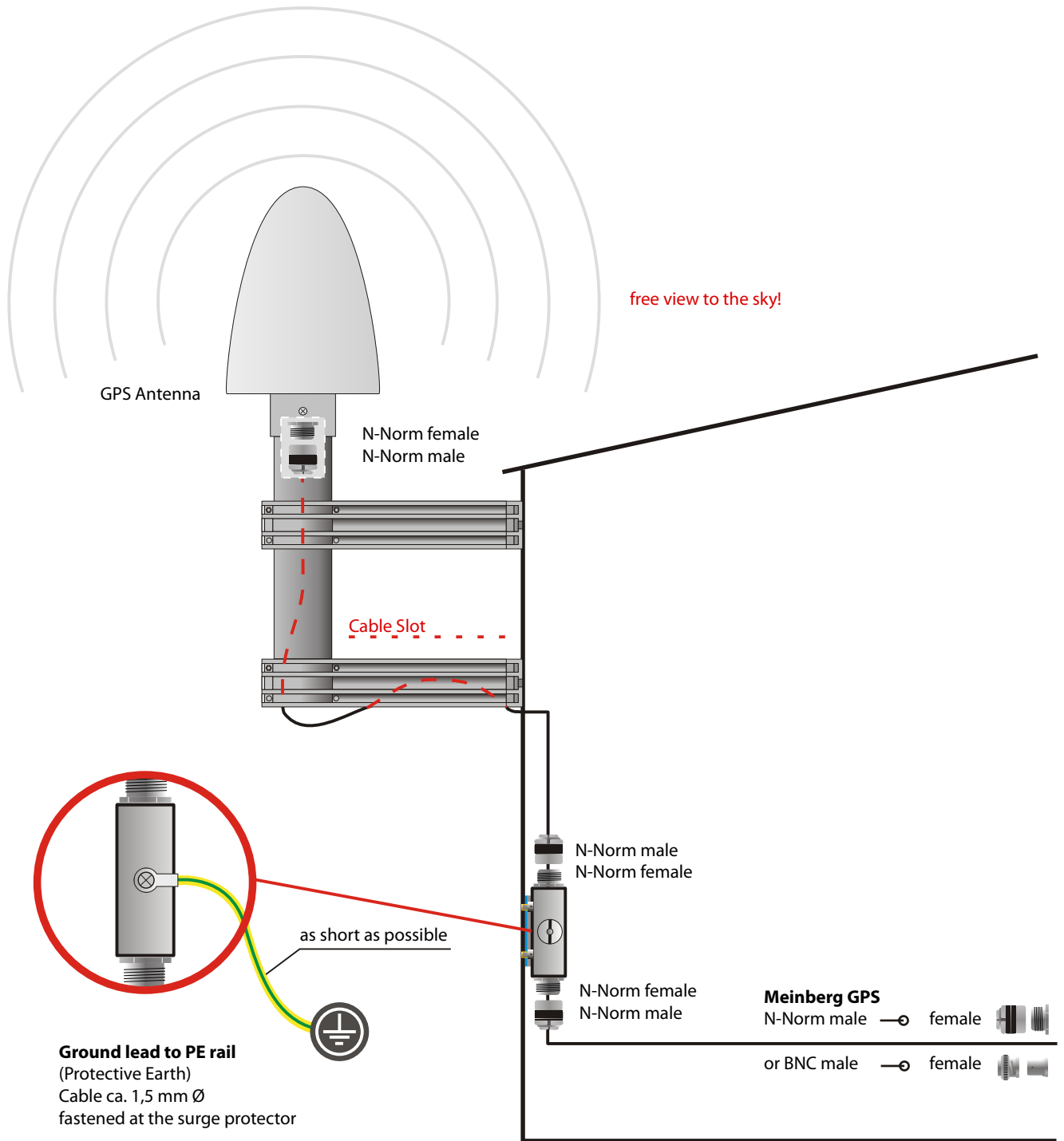

5.2 Powering Up the System

If both the antenna and the power supply have been connected the system is ready to operate. About 3 minutes the oscillator (OCXO-HQ) has warmed up and operates with the required accuracy. If the receiver finds valid almanac and ephemeris data in its battery buffered memory and the receiver's position has not changed significantly since its last operation the receiver can find out which satellites are in view now. Only a single satellite needs to be received to synchronize and generate output pulses, so synchronization can be achieved maximally 10 minutes after power-up (OCXO-HQ). After 20 minutes of operation the OCXO is full adjusted and the generated frequencies are within the specified tolerances.

If the receiver position has changed by some hundred kilometers since last operation, the satellites' real elevation and doppler might not match those values expected by the receiver thus forcing the receiver to start scanning for satellites. This mode is called Warm Boot because the receiver can obtain ID numbers of existing satellites from the valid almanac. When the receiver has found four satellites in view it can update its new position and switch to Normal Operation. If the almanac has been lost because the battery had been disconnected the receiver has to scan for a satellite and read in the current almanacs. This mode is called Cold Boot. It takes 12 minutes until the new almanac is complete and the system switches to Warm Boot mode scanning for other satellites.

In the default mode of operation, neither pulse and synthesizer outputs nor the serial ports will be enabled after power-up until synchronization has been achieved. However, it is possible to configure those outputs to be enabled immediately after power-up. If the system starts up in a new environment (e. g. receiver position has changed or new power supply) it can take some minutes until the OCXO's output frequency has been adjusted. Up to that time accuracy of frequency drops to 10^{-8} reducing the accuracy of pulses to $\pm 5\mu s$.

5.3 Quick Start Guide for Initial Operation

After the RD-GPS was connected to the power supply and the network, it can be configured and monitored by using Meinberg's Device Manager program.

The Meinberg Device Manager program can be downloaded here:

Windows: https://www.meinbergglobal.com/download/utils/windows/mbgdevman_setup.exe

Linux: <https://www.meinbergglobal.com/download/utils/linux/mbgdevman.tar.gz>

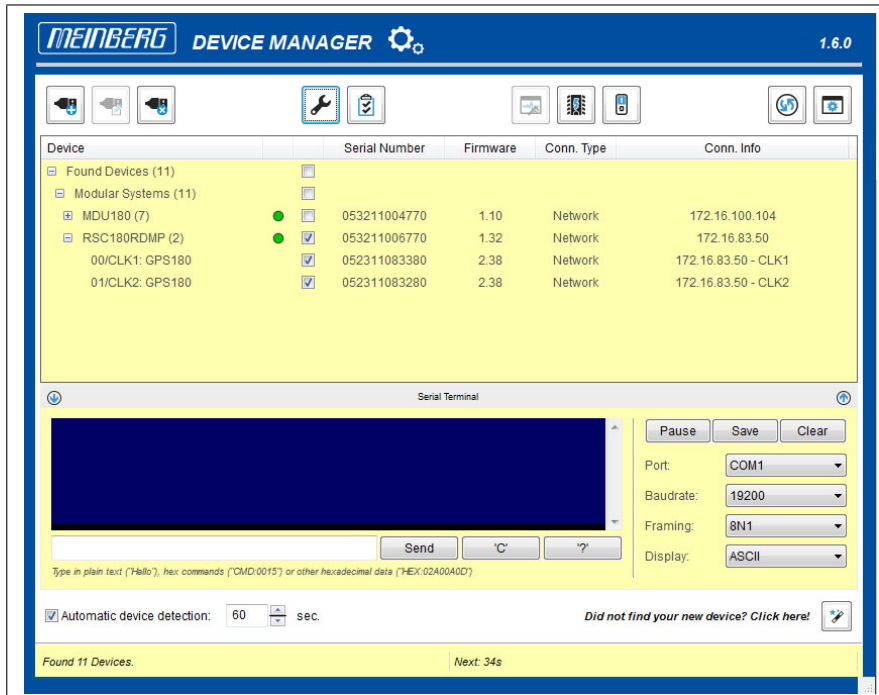

Configuration via the Network with the MEINBERG DEVICE MANAGER

After starting the "mbgdevman" all devices found in the network will be shown in the main window. By selecting the icon on the left side of the entry, all network addresses can be displayed. The LED icon indicates the status of the device. After selecting the checkbox, the edit / delete buttons are activated in the top left of the window.

The upper part (center) of the window also contains the buttons "Edit Device" and "Status". The Edit button opens the "Device configuration" window. All important settings can be made for all of the listed devices, or for the selected system:

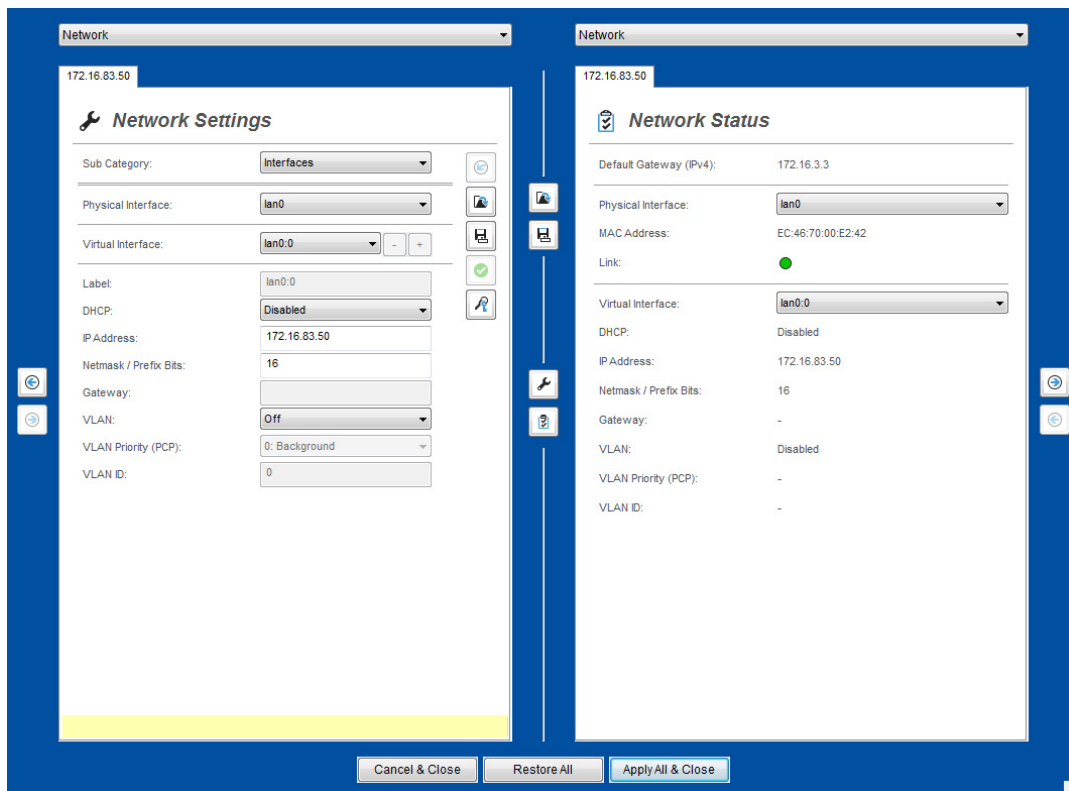

Network Settings - "Main"

After selecting "Main" in the Sub Category drop-down list you can enter the Hostname, Default Gateway, DNS Server and DNS Search Domain.

Network Settings - "Interfaces"

After selecting "Interfaces", the parameters for the LAN interface of the switch module can be configured:

- DHCP IPv4 or disabled
- IP Address if DHCP disabled
- Netmask if DHCP disabled
- VLAN On or Off
- VLAN Priority
- VLAN ID

Network Status

The current status of the network connection is displayed in the status window. If a network connection is available, a green circle is displayed at "Link". Information about the DNS server, DHCP, IP address, netmask, gateway and VLAN is also displayed here.

System Settings
Switch Method Remote Controlled / Front Panel Switch
Master Clock Clock 1 / Clock 2
Outputs Enabled / Disabled

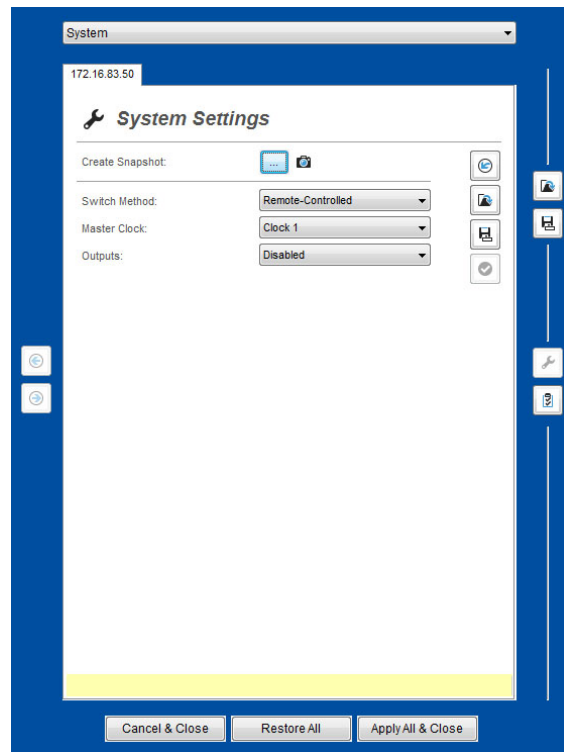

System Status
Switch Method Remote / Front Panel Switch
Master Clock Clock 1 / Clock 2
Power Supply PSU 1 / PSU 2

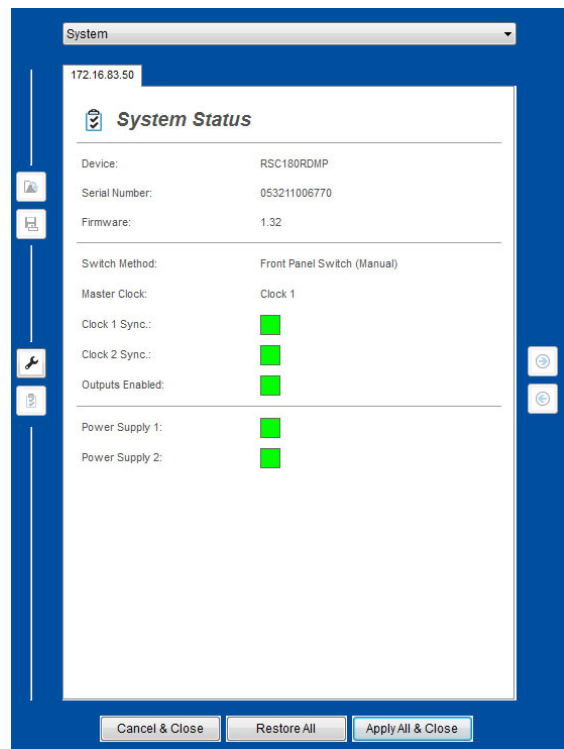

With double-clicking on the device entry you can adjust the connection type (the "Network" connection type and a serial connection are possible). Here you can also set a new password (default: mbg). By default, the DHCP service is enabled so that an IP address is assigned automatically.

If no DHCP server could be found or no IP address has been assigned via DHCP by any other reason, a fallback IP address 169.254.xxx.yyy will be set automatically (Zeroconf ¹).

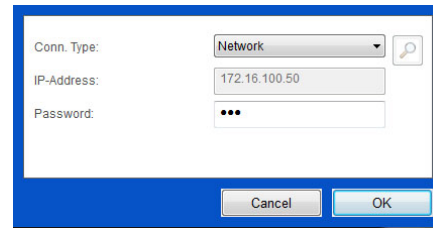

The image shows a network configuration dialog box with a blue border. It contains three input fields: "Conn. Type:" with a dropdown menu set to "Network" and a search icon; "IP-Address:" with a text box containing "172.16.100.50"; and "Password:" with a text box containing three dots. At the bottom right, there are "Cancel" and "OK" buttons.

¹Zeroconf: If a computer configures a link local IP address, it selects an IP address between 169.254.1.0 and 169.254.254.255 by using a random number generator.

6 The Front Panel Layout

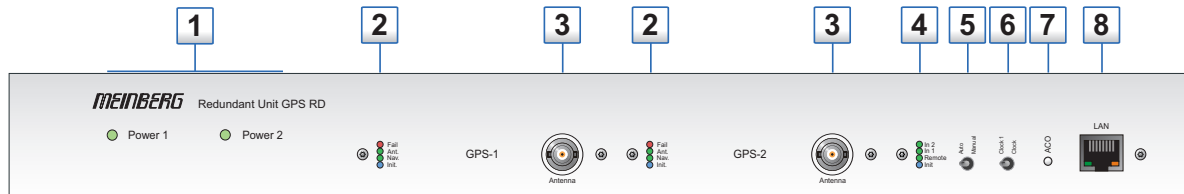

ENGLISH

1. Power supply Status-LEDs (Power 1 / Power 2)
2. GPS 1 / 2 Status-LEDs
3. GPS Antenna 1 / 2, BNC
4. Status-LEDs In1 (Clock 1) / In2 (Clock 2) / Remote / Init
5. Changeover switch "Clk 1 / Clk 2", "Auto / Man"
6. Changeover switch "Clk 1 / Clk 2"
7. ACO Button (Access Control Override)
8. Network connector "Remote Control", Rj45

DEUTSCH

1. Netzteil Status-LEDs (Power 1 / Power 2)
2. GPS 1 / 2 Status-LEDs
3. GPS Antenne 1 / 2, BNC
4. Status-LEDs Clock 1 / Clock 2 / Remote / Init
5. Umschalter "Clk 1 / Clk 2", "Auto / Man"
6. Umschalter "Clk 1 / Clk 2"
7. ACO Button (Access Control Override)
7. Netzwerk Anschluss "Remote Control", Rj45

6.1 Power LED

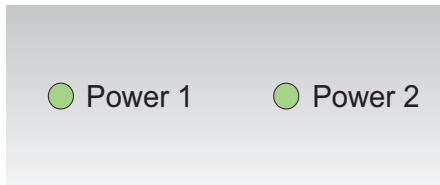

There is one led included in the front panel for each power supply, power 1 and power 2. These lights turn green as soon as the respective power supply is connected to the mains.

LED Anzeige

green: Powersupply in operation

off: Powersupply is defective or not correctly connected

6.2 GPS Receiver - Status LEDs

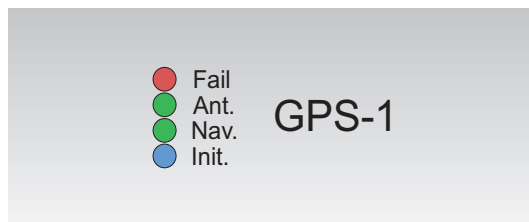

LED Indicators

Fail: red: time has not synchronized

Ant. Fail: red: antenna faulty or not connected

Nav. Solved: green: positioning successfully

Init: blue: while the receiver passes through the initialization phase
green: the oscillator has warmed up

6.3 GPS Antenna

Cable:	shielded coax
Cable Length:	max. 300m to RG58, max. 700m to RG213
Connector:	BNC female or N-type female
Input GPS:	Antenna circuit 1000 V DC insulated
Local Oscillator to Converter Frequency:	10 MHz ¹
First IF Frequency:	35.4 MHz ¹
	1) these frequencies are transferred via the antenna cable.
Power Requirements:	15 V, 100mA (via antenna cable)

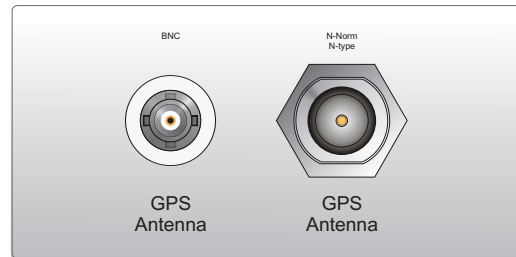

WARNING!

Working on the antenna system during thunderstorms



Danger to life due to electrical shock!

- Do not carry out any work on the antenna system or the antenna cable if there is a risk of a lightning strike.
- Do not carry out any work on the antenna system if the safety distance to free lines and sequential circuits is exceeded.

6.4 Status LEDs Switch Unit



This is an automatic multiplexer board for redundant clock systems composed of two Meinberg radio-clocks. It is used to perform changeovers on pulse and frequency signals as well as the serial ports of the connected radio clocks based on the status of the time-sync signals of both clocks. To avoid unnecessary changeovers in case of repeatedly occurring freewheeling operations of one system, the master/backup order is changed on each changeover. For example, suppose the current master system to loose synchronization.

Now a changeover is performed to the synchronous slave system and the previous slave system becomes the new Master. No changeover is done if both systems are asynchronous. In this case the current state is retained. All essential functions of the board, such as actual switching state, alarms and mode of operation can be monitored via SNMP/ETHERNET connection. Also changeover can be triggered remotely via SNMP command. Network access to the board is password protected. The board is capable of handling 10 MBit as well as 100 MBit ethernet connection over a front panel RJ45 connector. Two front panel switches allow override of the internal selection logic. Current State of the board is indicated by three front panel LEDs.

Front Panel Switch Automatic/Manual

This switch selects between automatic and manual mode. In manual mode the boards internal selection logic is overridden and the current system for signal generation can only be selected manually by the switch CLK1/CLK2. This switch also takes precedence over the Ethernet remote functions. In manual mode the outputs are always enabled, regardless of the synchronization state of the clocks.

LED IN1 / IN2

These Leds show the current switching state of the board. Both LEDs are turned off if the boards outputs are deactivated.

LED REMOTE

Indicates remote controlled operation over SNMP/ETHERNET. In remote mode the user can select the master via SNMP command. The last state selected over SNMP is retained when the system returns to local/automatic mode if this state is not inconsistent with the selection that would be made by the control logic. For example, if the user selects CLK2 as master system via SNMP, then this state is only retained on return to local mode, if either CLK 2 is synchronous or both clocks are asynchronous.

Init

This LED lights up blue, during the initialization of the RSC switch card.

Front Panel Switch IN1/IN2

Selects the active system in Manual Mode, has no effect in automatic mode.

ACO-Button (Access Control Override)

The button labelled ACO can be used if the access password has been forgotten. However, it only works if there is not a connection with the MEINBERG Device Manager. If it is pressed briefly (please press and hold for about 4 seconds), the set password will be reset for 30 seconds (to "nothing", i.e. You can simply press RETURN in the password query) and then put it back on the previous value. This is true for both Telnet setup and Mbgdevman connections. If a connection to the Mbgdevman is established during the 30 seconds, the "empty" password for the duration of this connection will remain in any case (even if this lasts longer than 30 seconds). In this case, the old password will not be active until you stop the connection. This ACO mode should only be used to enter a new password when the old one has been lost.

6.5 10/100base-T Ethernet (IEEE 803.2)

Link Speed:	10/100 MBit
Connector Type:	8P8C (RJ45)
Cable:	CAT 5.0
Duplex Modes:	Half/Full/Autonegotiaton

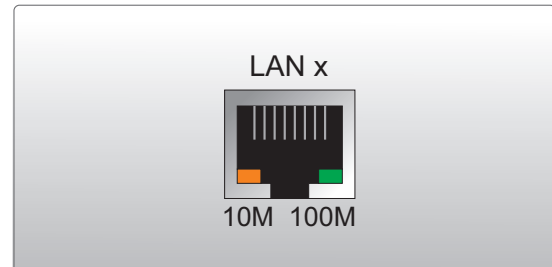

7 RSC-XPT

The RSC-XPT switch-unit module transfers the first serial port (COM0) of a Meinberg GNSS receiver into a 10BaseT/100BaseT Ethernet interface, adding functionality that allows a user to query status informations by using the TCP/IP Protocol and the Meinberg monitoring and management software "mbgdevman" or a third-party SNMP software. It is also possible to connect to the satellite receiver via network, reading the time and date telegrams generated by the clock. If configured, the module automatically queries the clock periodically and generates alarm messages (SNMP traps), which are sent to the SNMP management software. Additionally a configured syslog server can receive those alarm messages and record them for later reference.

8 Rear connectors

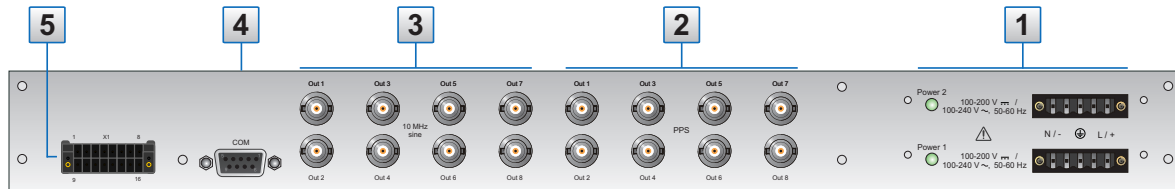

ENGLISH

1. Power supply connector
2. PPS outputs, BNC
3. 10 MHz sine outputs, BNC
4. Serial port COM 0, 9pin D-Sub female
5. Error Relay and Time- Status outputs, DMC-X1 connector

DEUTSCH

1. Spannungsversorgung
2. PPS Ausgänge, BNC
3. 10 MHz Sinus Ausgänge, BNC
4. Serielle Schnittstelle COM 0, 9pol D-Sub Buchse
5. Error Relais und Time- Status Ausgänge, DMC-X1 Stecker

Name	Connector	Type	Cable / Connection
Power supply 1/2	5pin DFK	100-240 V AC (50-60Hz) 100-200 V DC	5pin MSTB clamp
8 x PPS Out	BNC	TTL 2.5 V _{PP} into 50 Ohm	shielded coaxial line
8 x 10MHz Sine Out	BNC	5 dBm +/- 1 dBm	shielded coaxial line
COM	9pin D-SUB female	RS-232	shielded data line
Error X1	DMC connector	alarm relays	16pin DMC male connector

8.1 Power Connector

Connector Type:	5-pol. DFK
Pin Assignment:	1: N/- 2: not connected 3: PE (Potential Earth) 4: not connected 5: L/+

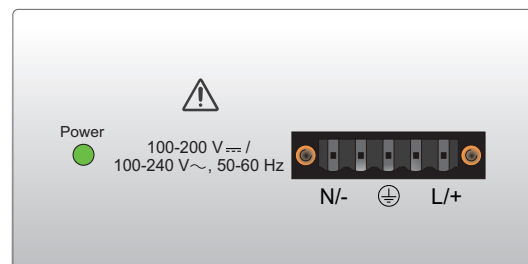

Input Parameter

Nominal Voltage Range: $U_N = 100-240 V_{\sim} / 100-200 V_{\text{DC}}$

Maximum Voltage Range: $U_{\text{max}} = 90-265 V_{\sim} / 90-250 V_{\text{DC}}$

Nominal Current: $I_N = 0.50 A$

Nominal Frequency Range: $f_N = 50-60 Hz$

Maximum Frequency Range: $f_{\text{max}} = 47-63 Hz$

Output Parameter

Maximum Power: $P_{\text{max}} = 50 W$

Maximum Heat: $BTU = 170,61 BTU/h$



WARNING!

This equipment is operated at a hazardous voltage.



Danger to life due to electrical shock!

- Only qualified personnel (electricians) may connect the device.
- Never work with open terminals and plugs while the power is on.
- All connectors must be protected against touching live parts with a suitable plug housing!
- Note: Always ensure safe wiring!
- Important: The device must be connected to a proper grounding (PE).

8.2 Pulse Per Second Output

Level:	TTL 2.5 V into 50 Ohm
Connector:	BNC, female
Cable:	shielded coax line
Pulse length:	200 ms

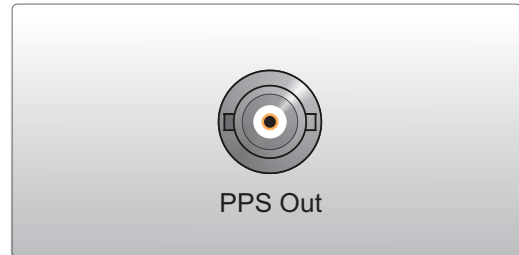

8.3 10 MHz sine Output

Frequency:	10 MHz sine wave
Level:	5 dBm +/- 1 dBm
Connector:	BNC, female
Impedance:	50 Ω
Port to port isolation:	45 dB
Harmonics:	< -60 dBc
Spurious:	< -65 dBc
Phase noise:	< -115 dBc/Hz at 10 Hz < -130 dBc/Hz at 100 Hz < -140 dBc/Hz at 1 KHz
Cable:	shielded coax line



8.4 RS232 COMx Timestring

Connector: 9pin D-SUB female

Cable: shielded data line

Assignment:

Pin 2: TxD (transmit)

Pin 3: RxD (receive)

Pin 5: GND (ground)

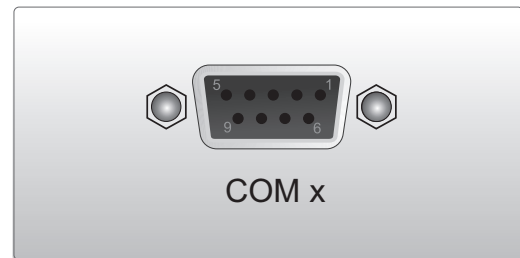

WARNING!

This equipment is operated at a hazardous voltage.



Danger to life due to electrical shock!

- Never work with open terminals and plugs while the power is on!
- When working on the connectors of the interface cable, always remove both sides of the cable from the respective devices!

The device is equipped with two potential-free and isolated serial interfaces. In the event of a fault in a connected device, dangerous voltages can occur at the signal lines of the serial interfaces.

8.5 DMC X1 Connector

Funtion

With the help of the time status signal, it is signalled which clock is currently active as the master.

In the switch position (auto), the RSC automatically selects the clock as the master, which is the first synchronous. A signal "High" (TTL-level) is then output either to pin 4 (TS1-out) or PIN 12 (TS2-out).

We operate the assembly in manual mode, the master clock can be selected via the IN1 (CLK1)/IN2 (CLK2) switch. In this case, a "high" (TTL level) is also output to pin 4 (TS1-out) or PIN 12 (TS2-out). The active clock is indicated by the corresponding led in the front panel IN1 (CLK1) or IN2 (CLK2).

Furthermore, this connection has a relay output with potential-free contact, which is directly controlled by the RSC-Unit. If one of the reference clocks are synchronous, the relay will pull on and the relay contact "No" is active. An error message is issued when both the two reference clocks are asynchronous. The Relay Contact "NC" is then active.

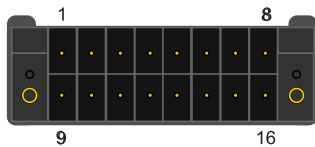

X1

Pin Assignment X1:	Pin 01:	REL-COM
	Pin 02:	N.C.
	Pin 03:	N.C.
	Pin 04:	TS1-Out
	Pin 05:	GND
	Pin 06:	N.C.
	Pin 07:	GND
	Pin 08:	N.C.
	Pin 09:	REL-NO
	Pin 10:	REL-NC
	Pin 11:	N.C.
	Pin 12:	TS2-Out
	Pin 13:	GND
	Pin 14:	N.C.
	Pin 15:	GND
	Pin 16:	N.C.

Technical Specification

Connector Type:	16pin DMC female connector	
Switching Voltage max.:	125 V DC 150 V AC	
Switching Current max.:	1 A	
Switching Load max.:	DC	30 W
	AC	60 VA
Switching Current UL/CSA:	0.46 A	150 V AC
	0.46 A	65 V DC
	1 A	30 V DC
Response Time:	ca.2 ms	

9 Firmware Updates

Whenever the on-board software of the receiver must be upgraded or modified, the new firmware can be downloaded to the internal flash memory via the serial COM port. There is no need to open the case and insert a new EPROM.

Set the Auto/Manual switch to the position "Manual", and select with the CLK1/CLK2 the GNSS-System which should be updated. Press the BSL Button on the front panel during the system is powered up. The bootstrap-loader is activated and waits for instructions from the serial COM port.

The new firmware can be sent to the GPS180 from any standard PC with serial interface (if no serial interface is available on the PC, then you need a "Serial → USB Converter"). The loader program (MBC Flash) will be shipped together with the file containing the image of the new firmware. The contents of the program memory will not be modified until the loader program has sent the command to erase the flash memory. To flash another receiver, select it with the switch and perform the update. To upload the Firmware to both clocks of a redundant system, the procedure of the update has to repeat.

After the next reboot, the system will be ready to operate again.

10 Technical Specifications GPS receiver

Receiver:	12 - channel C/A code receiver with external antenna/converter unit
Antenna:	Antenna/converter unit with remote power supply refer to chapter "Technical Specifications GPS Antenna"
Antenna Input:	Antenna circuit dc-insulated; dielectric strength: 1000 V Length of cable: refer to chapter "Mounting the Antenna"
Time to Synchronization:	One minute with known receiver position and valid almanac, 12 minutes if invalid battery buffered memory
Pulse Outputs:	Change of second (P_SEC, TTL level)
Accuracy of Pulses:	after synchronization and 20 minutes of operation OCXO HQ/DHQ: better than ± 50 nsec
Frequency Outputs:	10 MHz sine, 5 dBm \pm 1 dBm
Accuracy of Frequency:	see Oscillator specification
Serial Ports:	two asynchronous serial ports (RS-232)
	Baud Rate: 300 up to 19200
	Framing: 7E1, 7E2, 7N2, 7O1, 7O2, 8E1, 8N1, 8N2, 8O1
	default setting: COM: 19200, 8N1

10.1 Oscillator specifications

Verfügbare Oszillatoren für Meinberg GPS Empfänger und NTP Zeitserver:
OCXO, TCXO, Rubidium

	TCXO	OCXO LQ	OCXO SQ	OCXO MQ	OCXO HQ	OCXO DHQ	Rubidium (only available for 3U models)
Kurzzeitstabilität ($\tau = 1 \text{ sec}$)	$2 \cdot 10^{-9}$	$1 \cdot 10^{-9}$	$5 \cdot 10^{-10}$	$2 \cdot 10^{-10}$	$5 \cdot 10^{-12}$	$2 \cdot 10^{-12}$	$2 \cdot 10^{-11}$
Genauigkeit des PPS (Sekundenimpuls)	$< \pm 100 \text{ ns}$	$< \pm 100 \text{ ns}$	$< \pm 50 \text{ ns}$	$< \pm 50 \text{ ns}$	$< \pm 50 \text{ ns}$	$< \pm 50 \text{ ns}$	$< \pm 50 \text{ ns}$
Phasenrauschen	1Hz -60dBc/Hz 10Hz -90dBc/Hz 100Hz -120dBc/Hz 1kHz -130dBc/Hz	1Hz -60dBc/Hz 10Hz -90dBc/Hz 100Hz -120dBc/Hz 1kHz -130dBc/Hz	1Hz -70dBc/Hz 10Hz -105dBc/Hz 100Hz -125dBc/Hz 1kHz -140dBc/Hz	1Hz -75dBc/Hz 10Hz -110dBc/Hz 100Hz -130dBc/Hz 1kHz -140dBc/Hz	1Hz < -85dBc/Hz 10Hz < -115dBc/Hz 100Hz < -130dBc/Hz 1kHz < -140dBc/Hz	1Hz < -80dBc/Hz 10Hz < -110dBc/Hz 100Hz < -125dBc/Hz 1kHz < -135dBc/Hz	1Hz -75dBc/Hz 10Hz -89dBc/Hz 100Hz -128dBc/Hz 1kHz -140dBc/Hz
Genauigkeit freilaufend, ein Tag	$\pm 1 \cdot 10^{-7}$ $\pm 1 \text{ Hz (t)}$	$\pm 2 \cdot 10^{-8}$ $\pm 0.2 \text{ Hz (t)}$	$\pm 5 \cdot 10^{-9}$ $\pm 50 \text{ mHz (t)}$	$\pm 1.5 \cdot 10^{-9}$ $\pm 15 \text{ mHz (t)}$	$\pm 5 \cdot 10^{-10}$ $\pm 5 \text{ mHz (t)}$	$\pm 1 \cdot 10^{-10}$ $\pm 1 \text{ mHz (t)}$	$\pm 2 \cdot 10^{-11}$ $\pm 0.2 \text{ mHz (t)}$
Genauigkeit freilaufend, 1 Jahr	$\pm 1 \cdot 10^{-6}$ $\pm 10 \text{ Hz (t)}$	$\pm 4 \cdot 10^{-7}$ $\pm 4 \text{ Hz (t)}$	$\pm 2 \cdot 10^{-7}$ $\pm 2 \text{ Hz (t)}$	$\pm 1 \cdot 10^{-7}$ $\pm 1 \text{ Hz (t)}$	$\pm 5 \cdot 10^{-8}$ $\pm 0.5 \text{ Hz (t)}$	$\pm 1 \cdot 10^{-8}$ $\pm 0.1 \text{ Hz (t)}$	$\pm 5 \cdot 10^{-10}$ $\pm 5 \text{ mHz (t)}$
Genauigkeit GPS- synchron, 24h gemittelt	$\pm 1 \cdot 10^{-11}$	$\pm 1 \cdot 10^{-11}$	$\pm 1 \cdot 10^{-11}$	$\pm 5 \cdot 10^{-12}$	$\pm 1 \cdot 10^{-12}$	$\pm 1 \cdot 10^{-12}$	$\pm 1 \cdot 10^{-12}$
Genauigkeit der Zeit freilaufend, 1 Tag	$\pm 4.3 \text{ ms}$	$\pm 865 \mu\text{s}$	$\pm 220 \mu\text{s}$	$\pm 65 \mu\text{s}$	$\pm 22 \mu\text{s}$	$\pm 4.5 \mu\text{s}$	$\pm 1.1 \mu\text{s}$
Genauigkeit der Zeit freilaufend, 1 Jahr	$\pm 16 \text{ s}$	$\pm 6.3 \text{ s}$	$\pm 4.7 \text{ s}$	$\pm 1.6 \text{ s}$	$\pm 788 \text{ ms}$	$\pm 158 \text{ ms}$	$\pm 8 \text{ ms}$
Temperaturdrift freilaufend	$\pm 1 \cdot 10^{-6}$ (-20...70°C)	$\pm 2 \cdot 10^{-7}$ (0...60°C)	$\pm 1 \cdot 10^{-7}$ (-10...70°C)	$\pm 5 \cdot 10^{-8}$ (-20...70°C)	$\pm 1 \cdot 10^{-8}$ (5...70°C)	$\pm 2 \cdot 10^{-10}$ (5...70°C)	$\pm 6 \cdot 10^{-10}$ (-25...70°C)

Hinweis 1:

Die Genauigkeit in Hertz basiert auf der Normalfrequenz von 10MHz.

Zum Beispiel: Genauigkeit des TCXO (freilaufend, ein Tag) ist $\pm 1 \cdot 10^{-7} \cdot 10 \text{ MHz} = \pm 1 \text{ Hz}$

Die angegebenen Werte für die Zeit und Frequenzgenauigkeit (nicht Kurzzeitstabilität) sind nur für eine konstante Umgebungstemperatur gültig!
Es sind mindestens 24 Stunden GPS-Synchronität vor Freilauf erforderlich.

10.2 Technical Specifications GPS Antenna

Antenna:	dielectrical patch antenna, 25 x 25 mm receive frequency: 1575.42 MHz
Bandwith:	9 MHz
Converter:	local oscillator to converter frequency: 10 MHz first IF frequency: 35.4 MHz
Power Requirements:	12V ... 18V, @ 100mA (provided via antenna cable)
Connector:	N-Type, female
Ambient Temperature:	-40 ... +65°C
Housing:	ABS plastic case for outdoor installation (IP66)

Physical Dimension:

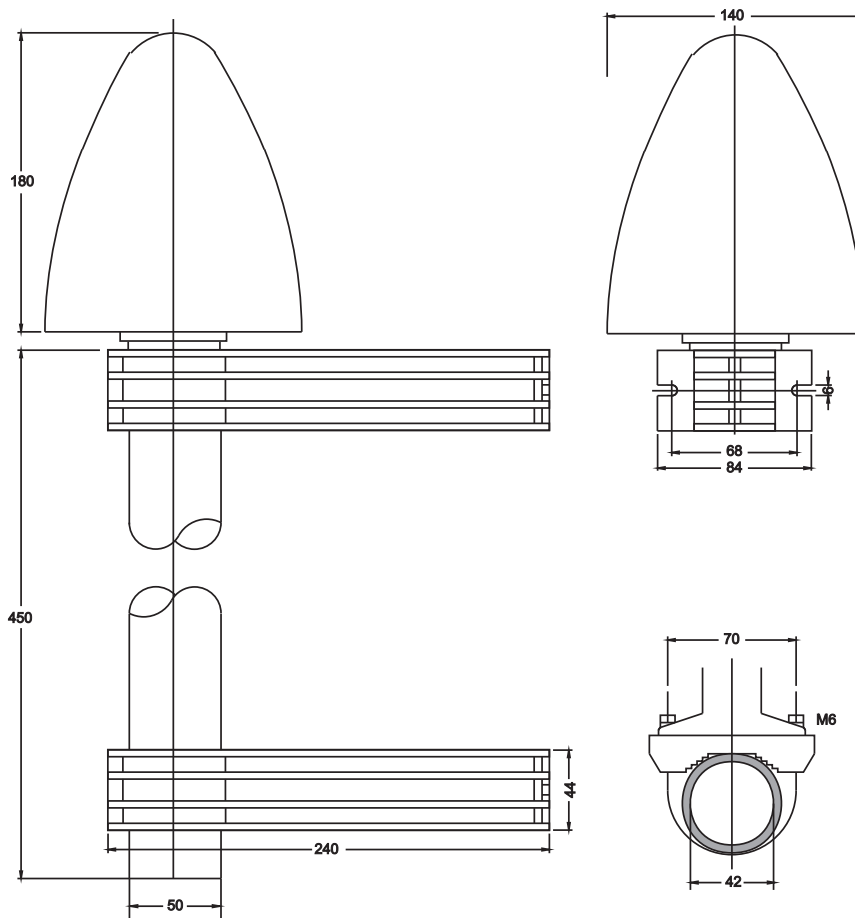

10.3 Time Strings

10.3.1 Format of the Meinberg Standard Time String

The Meinberg Standard Time String is a sequence of 32 ASCII characters starting with the STX (start-of-text) character and ending with the ETX (end-of-text) character. The format is:

`<STX>D:dd.mm.yy;T:w;U:hh.mm.ss;uvxy<ETX>`

The letters printed in italics are replaced by ASCII numbers whereas the other characters are part of the time string. The groups of characters as defined below:

<code><STX></code>	Start-Of-Text, ASCII Code 02h sending with one bit accuracy at change of second		
<code>dd.mm.yy</code>	the current date:		
<code>dd</code>	day of month	(01..31)	
<code>mm</code>	month	(01..12)	
<code>yy</code>	year of the century	(00..99)	
<code>w</code>	the day of the week	(1..7, 1 = Monday)	
<code>hh.mm.ss</code>	the current time:		
<code>hh</code>	hours	(00..23)	
<code>mm</code>	minutes	(00..59)	
<code>ss</code>	seconds	(00..59, or 60 while leap second)	
<code>uv</code>	clock status characters (depending on clock type):		
<code>u:</code>	<code>'#'</code>	GPS: clock is running free (without exact synchr.) PZF: time frame not synchronized DCF77: clock has not synchronized after reset	
	<code>' '</code>	(space, 20h) GPS: clock is synchronous (base accuracy is reached) PZF: time frame is synchronized DCF77: clock has synchronized after reset	
<code>v:</code>	<code>'*'</code>	GPS: receiver has not checked its position PZF/DCF77: clock currently runs on XTAL	
	<code>' '</code>	(space, 20h) GPS: receiver has determined its position PZF/DCF77: clock is synchronized with transmitter	
<code>x</code>	time zone indicator:		
	<code>'U'</code>	UTC	Universal Time Coordinated, formerly GMT
	<code>' '</code>	CET	European Standard Time, daylight saving disabled
	<code>'S'</code>		(CEST) European Summertime, daylight saving enabled
<code>y</code>	announcement of discontinuity of time, enabled during last hour before discontinuity comes in effect:		
	<code>'!</code>	announcement of start or end of daylight saving time	
	<code>'A'</code>	announcement of leap second insertion	
	<code>' '</code>	(space, 20h) nothing announced	
<code><ETX></code>	End-Of-Text, ASCII Code 03h		

10.3.2 Format of the Meinberg GPS Time String

The Meinberg Standard Time String is a sequence of 36 ASCII characters starting with the STX (start-of-text) character and ending with the ETX (end-of-text) character. Contrary to the Meinberg Standard Telegram the Meinberg GPS Timestrings carries no local timezone or UTC but the direct GPS time without conversion into UTC. The format is:

<STX>D:tt.mm.jj;T:w;U:hh.mm.ss;uvGy;lll<ETX>

The letters printed in *italics* are replaced by ASCII numbers whereas the other characters are part of the time string. The groups of characters as defined below:

<STX>	Start-Of-Text (ASCII code 02h)
tt.mm.jj	the current date: <i>tt</i> day of month (01..31) <i>mm</i> month (01..12) <i>jj</i> year of the century (00..99)
w	the day of the week (1..7, 1 = monday)
hh.mm.ss	the current time: <i>hh</i> hours (00..23) <i>mm</i> minutes (00..59) <i>ss</i> seconds (00..59, or 60 while leap second)
uv	clock status characters: <i>u</i> : '#' clock is running free (without exact synchr.) ' ' (space, 20h) clock is synchronous (base accuracy is reached) <i>v</i> : '*' receiver has not checked its position ' ' (space, 20h) receiver has determined its position
G	time zone indicator 'GPS-Time'
y	announcement of discontinuity of time, enabled during last hour before discontinuity comes in effect: 'A' announcement of leap second insertion ' ' (space, 20h) nothing announced
lll	number of leap seconds between UTC and GPS-Time (UTC = GPS-Time + number of leap seconds)
<ETX>	End-Of-Text, (ASCII Code 03h)

10.3.3 Format of the Meinberg Capture String

The Meinberg Capture String is a sequence of 31 ASCII characters terminated by a CR/LF (Carriage Return/-Line Feed) combination. The format is:

CHx_tt.mm.jj_hh:mm:ss.ffffff <CR><LF>

The letters printed in italics are replaced by ASCII numbers whereas the other characters are part of the time string. The groups of characters as defined below:

x 0 or 1 corresponding on the number of the capture input
 _ ASCII space 20h

dd.mm.yy the capture date:

dd	day of month	(01..31)
mm	month	(01..12)
yy	year of the century	(00..99)

hh:mm:ss.ffffff the capture time:

hh	hours	(00..23)
mm	minutes	(00..59)
ss	seconds	(00..59, or 60 while leap second)
ffffff	fractions of second, 7 digits	

<CR> Carriage Return, ASCII Code 0Dh

<LF> Line Feed, ASCII Code 0Ah

10.3.4 Format of the SAT Time String

The SAT Time String is a sequence of 29 ASCII characters starting with the STX (start-of-text) character and ending with the ETX (end-of-text) character. The format is:

`<STX>dd.mm.yy/w/hh:mm:ssxxxuv<ETX>`

The letters printed in italics are replaced by ASCII numbers whereas the other characters are part of the time string. The groups of characters as defined below:

<code><STX></code>	Start-Of-Text, ASCII Code 02h sending with one bit accuracy at change of second
<code>dd.mm.yy</code>	the current date:
dd	day of month (01..31)
mm	month (01..12)
yy	year of the century (00..99)
w	the day of the week (1..7, 1 = Monday)
<code>hh:mm:ss</code>	the current time:
hh	hours (00..23)
mm	minutes (00..59)
ss	seconds (00..59, or 60 while leap second)
<code>xxxx</code>	time zone indicator:
'UTC'	Universal Time Coordinated, formerly GMT
'CET'	European Standard Time, daylight saving disabled
'CEST'	European Summertime, daylight saving enabled
<code>u</code>	clock status characters:
'#'	clock has not synchronized after reset
' '	(space, 20h) clock has synchronized after reset
<code>v</code>	announcement of discontinuity of time, enabled during last hour before discontinuity comes in effect:
'!'	announcement of start or end of daylight saving time
' '	(space, 20h) nothing announced
<code><CR></code>	Carriage Return, ASCII Code 0Dh
<code><LF></code>	Line Feed, ASCII Code 0Ah
<code><ETX></code>	End-Of-Text, ASCII Code 03h

10.3.5 Format of the Uni Erlangen String (NTP)

The time string Uni Erlangen (NTP) of a GPS clock is a sequence of 66 ASCII characters starting with the STX (start-of-text) character and ending with the ETX (end-of-text) character. The format is:

<STX>*tt.mm.jj*; *w*; *hh:mm:ss*; *voo:oo*; *acdfg i;bbb.bbbbn lll.lllle hhhhm*<ETX>

The letters printed in italics are replaced by ASCII numbers whereas the other characters are part of the time string. The groups of characters as defined below:

<STX>	Start-Of-Text, ASCII Code 02h sending with one bit accuracy at change of second
dd.mm.yy	the current date: dd day of month (01..31) mm month (01..12) yy year of the century (00..99) w the day of the week (1..7, 1 = Monday)
hh.mm.ss	the current time: hh hours (00..23) mm minutes (00..59) ss seconds (00..59, or 60 while leap second)
v	sign of the offset of local timezone related to UTC
oo:oo	offset of local timezone related to UTC in hours and minutes
ac	clock status characters: a: '#' clock has not synchronized after reset ' ' (space, 20h) clock has synchronized after reset c: '*' GPS receiver has not checked its position ' ' (space, 20h) GPS receiver has determined its position
d	time zone indicator: 'S' CEST European Summertime, daylight saving enabled ' ' CET European Standard Time, daylight saving disabled
f	announcement of discontinuity of time, enabled during last hour before discontinuity comes in effect: '!' announcement of start or end of daylight saving time ' ' (space, 20h) nothing announced
g	announcement of discontinuity of time, enabled during last hour before discontinuity comes in effect: 'A' announcement of leap second insertion ' ' (space, 20h) nothing announced
i	leap second insertion 'L' leap second is actually inserted (active only in 60th sec.) ' ' (space, 20h) no leap second is inserted
bbb.bbbb	latitude of receiver position in degrees leading signs are replaced by a space character (20h)
n	latitude, the following characters are possible: 'N' north of equator

'S' south d. equator

ll.llll longitude of receiver position in degrees
leading signs are replaced by a space character (20h)

e longitude, the following characters are possible:
'E' east of Greenwich
'W' west of Greenwich

hhhh altitude above WGS84 ellipsoid in meters
leading signs are replaced by a space character (20h)

<ETX> End-Of-Text, ASCII Code 03h

10.3.6 Format of the NMEA 0183 String (RMC)

The NMEA String is a sequence of 65 ASCII characters starting with the '\$GPRMC' character and ending with the characters CR (carriage return) and LF (line-feed). The format is:

```
$GPRMC,hhmmss.ss,A,bbbb.bb,n,llll.ll,e,0.0,0.0,ddmmyy,0.0,a*hh<CR><LF>
```

The letters printed in italics are replaced by ASCII numbers or letters where as the other characters are part of the time string. The groups of characters as defined below:

\$	Start character, ASCII Code 24h sending with one bit accuracy at change of second
hhmmss.ss	the current time: hh hours (00..23) mm minutes (00..59) ss seconds (00..59, or 60 while leap second) ss fractions of seconds (1/10 ; 1/100)
A	Status (A = time data valid) (V = time data not valid)
bbbb.bb	latitude of receiver position in degrees leading signs are replaced by a space character (20h)
n	latitude, the following characters are possible: 'N' north of equator 'S' south d. equator
llll.ll	longitude of receiver position in degrees leading signs are replaced by a space character (20h)
e	longitude, the following characters are possible: 'E' east of Greenwich 'W' west of Greenwich
ddmmyy	the current date: dd day of month (01..31) mm month (01..12) yy year of the century (00..99)
a	magnetic variation
hh	checksum (EXOR over all characters except '\$' and '*')
<CR>	Carriage Return, ASCII Code 0Dh
<LF>	Line Feed, ASCII Code 0Ah

10.3.7 Format of the NMEA 0183 String (GGA)

The NMEA (GGA) String is a sequence of characters starting with the '\$GPRMC' character and ending with the characters CR (carriage return) and LF (line-feed). The format is:

\$GPGGA,*hhmmss.ss,bbbb.bbbbb,n,llll.ll,e,A,vv,hhh.h,aaa.a,M,ggg.g,M,,0cs<CR><LF>**

The letters printed in italics are replaced by ASCII numbers or letters where as the other characters are part of the time string. The groups of characters as defined below:

\$	Start character, ASCII Code 24h sending with one bit accuracy at change of second
hhmmss.ss	the current time: hh hours (00..23) mm minutes (00..59) ss seconds (00..59, or 60 while leap second) ss fractions of seconds (1/10 ; 1/100)
A	Status (A = time data valid) (V = time data not valid)
bbbb.bbbbb	latitude of receiver position in degrees leading signs are replaced by a space character (20h)
n	latitude, the following characters are possible: 'N' north of equator 'S' south d. equator
llll.lllll	longitude of receiver position in degrees leading signs are replaced by a space character (20h)
e	longitude, the following characters are possible: 'E' east of Greenwich 'W' west of Greenwich
A	Position fix (1 = yes, 0 = no)
vv	Satellites used (0..12)
hhh.h	HDOP (Horizontal Dilution of Precision)
aaa.h	Mean Sea Level altitude (MSL = altitude of WGS84 - Geoid Separation)
M	Units, meters (fixed value)
ggg.g	Geoid Separation (altitude of WGS84 - MSL)
M	Units, meters (fixed value)
cs	checksum (EXOR over all characters except '\$' and '*')
<CR>	Carriage Return, ASCII Code 0Dh
<LF>	Line Feed, ASCII Code 0Ah

10.3.8 Format of the NMEA 0183 String (ZDA)

The NMEA String is a sequence of 38 ASCII characters starting with the '\$GPZDA' character and ending with the characters CR (carriage return) and LF (line-feed). The format is:

\$GPZDA, *hhmmss.ss, dd, mm, yyyy, HH, IIcs<CR><LF>**

ZDA - Time and Date: UTC, day, month, year and local timezone.

The letters printed in italics are replaced by ASCII numbers or letters where as the other characters are part of the time string. The groups of characters as defined below:

\$ Start character, ASCII Code 24h
sending with one bit accuracy at change of second

hhmmss.ss the current UTC time:
 hh hours (00..23)
 mm minutes (00..59)
 ss seconds (00..59 or 60 while leap second)

HH,II the local timezone (offset to UTC):
 HH hours (00..+-13)
 II minutes (00..59)

dd,mm,yy the current date:
 dd day of month (01..31)
 mm month (01..12)
 yyyy year (0000..9999)

cs checksum (EXOR over all characters except '\$' and '*')

<CR> Carriage Return, ASCII Code 0Dh

<LF> Line Feed, ASCII Code 0Ah

10.3.9 Format of the ABB SPA Time String

The ABB SPA Time String is a sequence of 32 ASCII characters starting with the characters ">900WD" and ending with the <CR> (Carriage Return) character. The format is:

>900WD:*yy-mm-tt_hh.mm;ss.fff*:cc<CR>

The letters printed in italics are replaced by ASCII numbers whereas the other characters are part of the time string. The groups of characters as defined below:

yy-mm-tt the current date:

yy year of the century (00..99)

mm month (01..12)

dd day of month (01..31)

– Space (ASCII code 20h)

hh.mm;ss.fff the current time:

hh hours (00..23)

mm minutes (00..59)

ss seconds (00..59, or 60 while leap second)

fff milliseconds (000..999)

cc Check sum. EXCLUSIVE-OR result of the previous characters, displayed as a HEX byte (2 ASCII characters 0..9 or A..F)

<CR> Carriage Return, ASCII Code 0Dh

10.3.10 Format of the Computime Time String

The Computime time string is a sequence of 24 ASCII characters starting with the T character and ending with the LF (line feed, ASCII Code 0Ah) character. The format is:

T:yy:mm:dd:ww:hh:mm:ss<CR><LF>

The letters printed in italics are replaced by ASCII numbers whereas the other characters are part of the time string. The groups of characters as defined below:

T	Start character sending with one bit accuracy at change of second
yy:mm:dd	the current date:
yy	year of the century (00..99)
mm	month (01..12)
dd	day of month (01..31)
ww	the day of the week (01..07, 01 = monday)
hh:mm:ss	the current time:
hh	hours (00..23)
mm	minutes (00..59)
ss	seconds (00..59, or 60 while leap second)
<CR>	Carriage Return, ASCII Code 0Dh
<LF>	Line Feed, ASCII Code 0Ah

10.3.11 Format of the RACAL standard Time String

The RACAL standard Time String is a sequence of 16 ASCII characters terminated by a X (58h) character and ending with the CR (Carriage Return, ASCII Code 0Dh) character. The format is:

<X><G><U>yymmddhhmmss<CR>

The letters printed in italics are replaced by ASCII numbers whereas the other characters are part of the time string. The groups of characters as defined below:

<X>	Control character sending with one bit accuracy at change of second	code 58h
<G>	Control character	code 47h
<U>	Control character	code 55h
yymmdd	the current date:	
yy	year of the century	(00..99)
mm	month	(01..12)
dd	day of month	(01..31)
hh:mm:ss	the current time:	
hh	hours	(00..23)
mm	minutes	(00..59)
ss	seconds	(00..59, or 60 while leap second)
<CR>	Carriage Return, ASCII code 0Dh	

Interface
parameters: 7 Databits, 1 Stopbit, odd. Parity, 9600 Bd

10.3.12 Format of the SYSPLEX-1 Time String

The SYSPLEX1 time string is a sequence of 16 ASCII characters starting with the SOH (Start of Header) ASCII control character and ending with the LF (line feed, ASCII Code 0Ah) character.

Please note:

To receive the Timestring on a selected terminal correctly you have to send a " C " (once, without quotation marks).

The format is:

`<SOH>ddd:hh:mm:ssq<CR><LF>`

The letters printed in italics are replaced by ASCII numbers whereas the other characters are part of the time string. The groups of characters as defined below:

<code><SOH></code>	Start of Header (ASCII control character) sending with one bit accuracy at change of second
<code>ddd</code>	day of year (001..366)
<code>hh:mm:ss</code>	the current time:
hh	hours (00..23)
mm	minutes (00..59)
ss	seconds (00..59, or 60 while leap second)
q	Quality indicator (space) Time Sync (GPS lock) (?) no Time Sync (GPS fail)
<code><CR></code>	Carriage-return (ASCII code 0Dh)
<code><LF></code>	Line-Feed (ASCII code 0Ah)

10.3.13 Format of the ION Time String

The ION time string is a sequence of 16 ASCII characters starting with the SOH (Start of Header) ASCII control character and ending with the LF (line feed, ASCII Code 0Ah) character. The format is:

`<SOH>ddd:hh:mm:ssq<CR><LF>`

The letters printed in italics are replaced by ASCII numbers whereas the other characters are part of the time string. The groups of characters as defined below:

<code><SOH></code>	Start of Header (ASCII control character) sending with one bit accuracy at change of second
<code>ddd</code>	day of year (001..366)
<code>hh:mm:ss</code>	the current time:
hh	hours (00..23)
mm	minutes (00..59)
ss	seconds (00..59, or 60 while leap second)
q	Quality indicator (space) Time Sync (GPS lock) (?) no Time Sync (GPS fail)
<code><CR></code>	Carriage-return (ASCII code 0Dh)
<code><LF></code>	Line-Feed (ASCII code 0Ah)



RD_GPS-HQ-2_FS-8_PS-8_RPS_MP_180618