

Technical Information
Operating Instructions
GPSGEN1575/MP

Impressum

Werner Meinberg
Lange Wand 9
D-31812 Bad Pyrmont

Phone: ++49 52 81 - 9309-0
Fax: ++49 52 81 - 9309-30

Internet: <http://www.meinberg.de>
Email: info@meinberg.de

March 09, 2010

Table of Contents

Impressum.....	2
Content of the USB stick	4
General information.....	5
The modular system GPSGEN1575/MP	6
Block diagram	6
Features GPSGEN1575/MP	7
Time zone and daylight saving	7
GPS outputs	8
IF outputs.....	8
Pulse output	8
Asynchronous serial ports	8
Enabling of outputs	9
Status Output	9
Installation	10
Power supply	10
Mounting the antenna.....	10
Assembly with CN-UB/E (CN-UB-280DC)	11
Powering up the system	12
LEDs in the front panel.....	13
FAIL LED	13
LOCK LED	13
Skilled/service-personnel only: Replacing the Lithium battery	14
Technical specifications GPSGEN1575/MP	14
Front/rear panel connectors	14
Technical data error relay	15
CE Label	15
Rear view GPSGEN1575/MP	16

SUB-D assignment	17
Connector assignments error relay (Time Sync)	17
Technical specifications GPSGEN1575	18
Format of the Meinberg Standard Time String	20
Format of the SAT-Time String	21
Format of the Uni Erlangen String (NTP)	22
Format of the ABB SPA Time String	24
Signal description GPSGEN1575	25
Rear connector pin assignments GPSGEN1575	26
Technical specifications power supply (T-60B)	27
Technical specifications of optional GPS antenna	28
The program GPSMON32	29
Serial Connection	29
Network Connection	29
Online Help	30

Content of the USB stick

Besides this manual, the provided USB stick includes a setup program for the monitor software GPSMON32. This utility can be used to configure Meinberg GPS receivers via their serial ports and display status information of the module.

The software is executable under the following operating systems:

- Windows Server 2003
- Windows XP
- Windows 2000
- Windows NT
- Windows ME
- Windows 9x

If the USB stick is lost, the setup program can be downloaded for free at:

<http://www.meinberg.de/english/sw/#gpsmon>

General information

The module GPSGEN1575/MP was designed to reconvert the intermediate frequency of 35.42 MHz transmitted on the antenna cable of Meinberg GPS clocks into the original GPS frequency of 1575.42 MHz. This technology allows the connection of GPS receivers of other manufacturers working without IF-technique to a Meinberg antenna with up to 300 meters of coaxial cable RG58 without the need of an additional amplifier. Besides the signal conditioning, GPSGEN1575/MP contains a complete GPS receiver which can be used as a reference in test applications. The internal mixture frequency is derived from a highly-stable TCXO which is locked to the GPS system.

The Global Positioning System (GPS) is a satellite-based radio-positioning, navigation, and time-transfer system. It was installed by the United States Department of Defense and provides two levels of accuracy: The Standard Positioning Service (SPS) and the Precise Positioning Service (PPS). While PPS is encrypted and only available for authorized (military) users, SPS has been made available to the general public.

GPS is based on accurately measuring the propagation time of signals transmitted from satellites to the user's receiver. A nominal constellation of 21 satellites together with several active spares in six orbital planes 20000 km over ground provides a minimum of four satellites to be in view 24 hours a day at every point of the globe. Four satellites need to be received simultaneously if both receiver position (x, y, z) and receiver clock offset from GPS system time must be computed. All the satellites are monitored by control stations which determine the exact orbit parameters as well as the clock offset of the satellites' on-board atomic clocks. These parameters are uploaded to the satellites and become part of a navigation message which is retransmitted by the satellites in order to pass that information to the user's receiver.

The high precision orbit parameters of a satellite are called ephemeris parameters whereas a reduced precision subset of the ephemeris parameters is called a satellite's almanac. While ephemeris parameters must be evaluated to compute the receiver's position and clock offset, almanac parameters are used to check which satellites are in view from a given receiver position at a given time. Each satellite transmits its own set of ephemeris parameters and almanac parameters of all existing satellites.

The modular system GPSGEN1575/MP

The modular system is a set of equipment composed of a GPS-signal converter GPSGEN1575, a GPS antenna diplexer GPSAV4 and a power supply unit T60B, installed in a metal desktop case (19", 1U) and ready to operate. The interfaces provided by GPSGEN1575 are accessible via connectors in the front or rear panel of the case. Details of the components are described below.



Block diagram

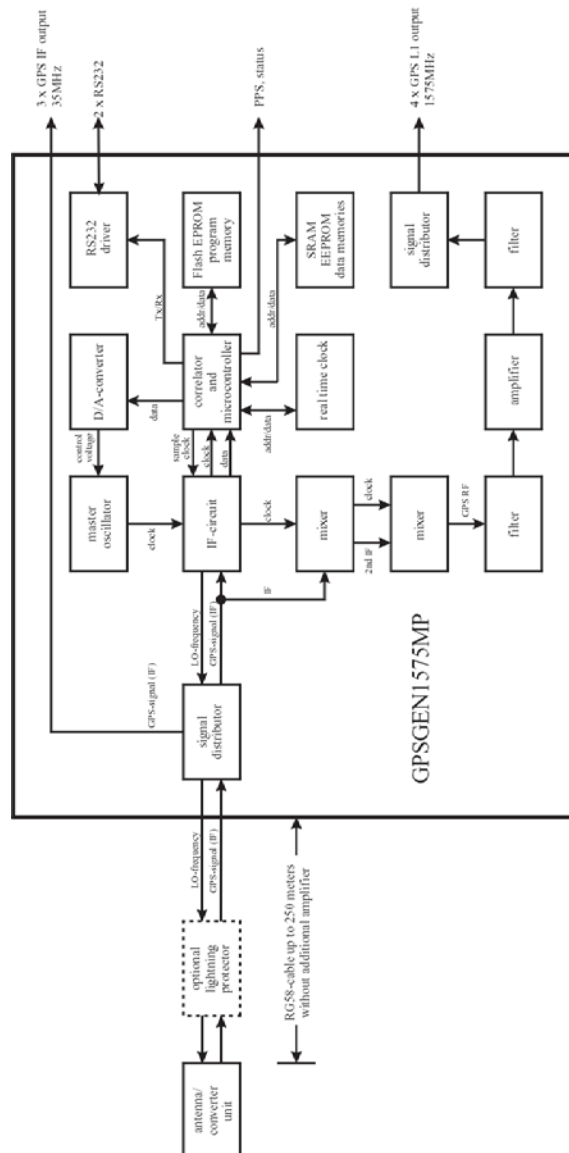

Features GPSGEN1575/MP

The integrated eurocard GPSGEN1575 includes a complete GPS receiver and a signal conditioning circuit for reconversion of the IF frequency (35.42MHz) transmitted on the antenna cable of Meinberg GPS clocks into the original GPS frequency (1575.42MHz).

The receiver circuit of the board is connected to the antenna/converter unit by a 50 Ω coaxial cable (refer to „Mounting the Antenna“). The power supply for the antenna/converter is provided by GPSGEN1575 DC insulated via the antenna cable.

GPSGEN1575 is using the "Standard Positioning Service" SPS. The altitude with its variation of $\pm 180\text{m}$ is the most inaccurate component of the position. This inaccuracy is caused by the operator (United States Department of Defense) and not by the receiver, but it has no influence on the accuracy of the generated time. The navigation message coming in from the satellites is decoded by the board's microprocessor in order to track the GPS system time. Compensation of the RF signal's propagation delay is done by automatical determination of the receiver's position on the globe.

A correction value computed from the satellites' navigation messages increases the accuracy of the board's temperature compensated master oscillator (TCXO) and automatically compensates the TCXO's aging. The last recent value is restored from the battery buffered memory at power-up.

Time zone and daylight saving

GPS system time differs from the universal time scale UTC (Universal Time Coordinated) by the number of leap seconds which have been inserted into the UTC time scale after GPS has been initiated in 1980. The current number of leap seconds is part of the navigation message supplied by the satellites, so GPSGEN1575's internal real time is based on UTC.

Conversion to local time including handling of daylight saving year by year can be done by the receiver's microprocessor if the corresponding parameters are set up with the help of the software GPSSMON32 (included Windows software). The GPS outputs are not affected by these settings.

GPS outputs

GPSGEN1575 uses two different paths to process the incoming signal of the antenna/converter unit. One receive section works as a standard GPS receiver, the other is used to reconvert the IF-frequency of a Meinberg antenna/converter into the original GPS frequency band with a RF of 1575.42 MHz.

After filtering and amplifying the received signal, it is applied to a mixer stage which translates the IF directly into the GPS band. This conversion product is filtered and amplified before it is distributed to four outputs by an impedance matching section. The GPS output signals are available via female N-connectors in the rear panel of GPSGEN1575/MP.

IF outputs

The integrated module GPSAV4 distributes the signal from the antenna input to GPSGEN1575 (internal) and three IF outputs that are available via female BNC-connectors in the rear panel. These outputs can be used for synchronization of other Meinberg GPS receivers.

Pulse output

The pulse generator of the converter GPSGEN1575 generates a high-active TTL pulse per second (PPS) with a pulse duration of 1 msec. The turn-on slope of this pulse is phase aligned to UTC-second. The pulse per second is available via a SUB-D connector in the rear panel of the case.

Asynchronous serial ports

Two asynchronous serial interfaces (RS-232) called COM0 and COM1 are available to the user. Transmission speeds, framings and the kind of the time string can be configured separately. The serial ports are sending a time string either once per second, once per minute or on request with ASCII '?' only. Possible time strings are described in the technical specifications.

Enabling of outputs

In the default mode of operation the pulse output (PPS) and the serial interfaces are disabled until the receiver has synchronized after power-up. However, with the help of the monitor program GPSMON32 the system can be configured to enable those outputs immediately after power-up. This option can be set for each group of signals (pulses and serial interfaces) separately.

Status Output

GPSGEN1575 provides an output indicating the status of time synchronization of the module. This status is available as a relay output with changeover contact via a SUB-D connector in the rear panel.

Installation

Power supply

The type of power supply needed for operation of GPSGEN1575/MP can be found in the chapter „Technical data power supply“ at the end of this manual.

Mounting the antenna

The GPS satellites are not stationary but circle round the globe in a period of about 12 hours. They can only be received if no building is in the line-of-sight from the antenna to the satellite, so the antenna/converter unit must be installed in a location from which as much of the sky as possible can be seen. The best reception is given when the antenna has a free view of 8° angular elevation above horizon. If this is not possible the antenna should be installed with a mostly free view to the equator because of the satellite courses which are located between latitudes of 55° North and 55° South.

If even this is not possible problems occur especially when at least four satellites for positioning have to be found.

The unit can be mounted using a pole with a diameter up to 60 mm. A standard coaxial cable with 50 Ω impedance (e.g. RG58C) should be used to connect the antenna/converter unit to the receiver. Cable thinner than RG58 should be avoided due to its higher DC resistance and RF attenuation. When using the optional antenna diplexer the total length of one antenna line between antenna, diplexer and receiver must not be longer than 300 m. If a cable with less attenuation is used its length may be increased accordingly (e.g. 600 m with RG213).

If an optional overvoltage protection device CN-UB/E (CN-UB-280DC) is used, please note that it should be installed directly after the antenna cable enters the building.

Assembly with CN-UB/E (CN-UB-280DC)

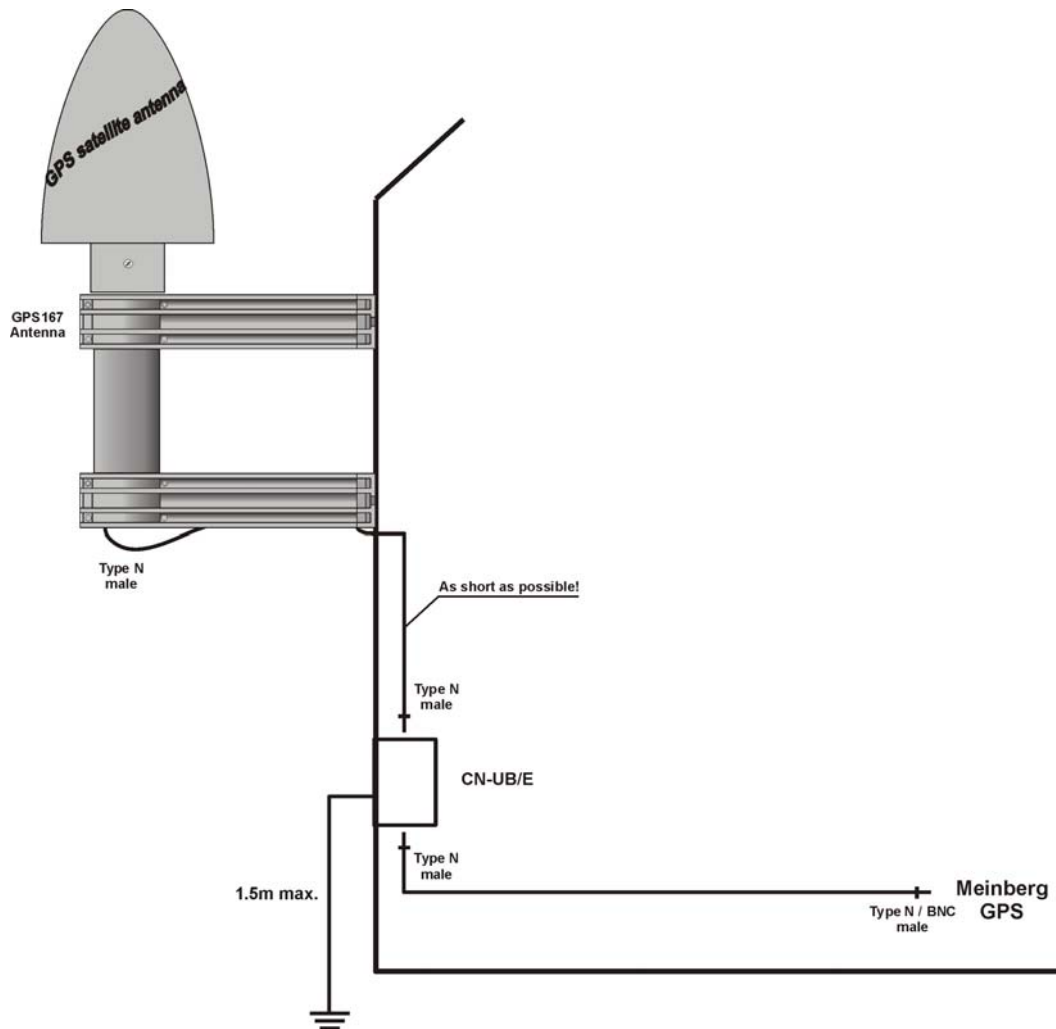

Powering up the system

If both the antenna and the power supply have been connected the system is ready to operate. About 10 seconds after power-up the receiver's TCXO has warmed up and operates with the required accuracy. If the receiver finds valid almanac and ephemeris data in its battery buffered memory and the receiver's position has not changed significantly since its last operation the receiver can find out which satellites are in view now. Only a single satellite needs to be received to synchronize and generate output pulses, so synchronization can be achieved maximally one minute after power-up. After 20 minutes of operation the TCXO is full adjusted and the generated frequency is within the specified tolerances.

If the receiver position has changed by some hundred kilometers since last operation, the satellites' real elevation and doppler might not match those values expected by the receiver thus forcing the receiver to start scanning for satellites. This mode is called **Warm Boot** because the receiver can obtain ID numbers of existing satellites from the valid almanac. When the receiver has found four satellites in view it can update its new position and switch to **Normal Operation**. If the almanac has been lost because the battery had been disconnected the receiver has to scan for a satellite and read in the current almanacs. This mode is called **Cold Boot**. It takes 12 minutes until the new almanac is complete and the system switches to **Warm Boot** mode scanning for other satellites.

In the default mode of operation, neither pulse nor the serial ports will be enabled after power-up until synchronization has been achieved. However, it is possible to configure some or all of those outputs to be enabled immediately after power-up. If the system starts up in a new environment (e. g. receiver position has changed or new power supply) it can take some minutes until the TCXO's output frequency has been adjusted. Up to that time accuracy of frequency drops to 10^{-8} reducing the accuracy of pulses to $\pm 5\mu\text{s}$.

LEDs in the front panel

FAIL LED

The FAIL LED is turned on whenever the TIME_SYN output is low (receiver is not synchronized).

LOCK LED

The LOCK LED is turned on when after power-up the receiver has acquired at least four satellites and has computed its position. In normal operation the receiver position is updated continuously as long as at least four satellites can be received.

Skilled/service-personnel only: Replacing the Lithium battery

The life time of the lithium battery on the board is at least 10 years. If the need arises to replace the battery, the following should be noted:

ATTENTION!

Danger of explosion in case of inadequate replacement of the lithium battery. Only identical batteries or batteries recommended by the manufacturer must be used for replacement. The waste battery must be disposed as proposed by the manufacturer of the battery.

Technical specifications GPSGEN1575/MP

HOUSING: Metal desktop case, MULTIPAC Schroff
Front panel: 1 U / 84 HP (43.6 mm high / 426.4 mm wide)

PROTECTION
RATING: IP20

PHYSICAL
DIMENSIONS: 482,6 mm wide x 43,7 mm high x 285 mm deep

Front/rear panel connectors

Name	Type	Signal	Cable
COM0	9 pin SUB-D	RS-232	shielded data line
COM1	9 pin SUB-D	RS-232	shielded data line
Pulse output (PPS)	9 pin SUB-D	TTL into 50 Ω	shielded coaxial line
Error Relay	9 pin SUB-D	Relay, make contact	
Antenna	Coax type N	10 MHz / 35.4 MHz	shielded coaxial line
GPS L1-OUT	Coax type N	1575 MHz	shielded coaxial line
GPS IF-OUT	Coax type BNC	35.4 MHz	shielded coaxial line
Power supply	power cord receptacle EN60320-C13	100 ... 240V AC	power supply cord

Technical data error relay

SWITCHING VOLTAGE:	48 VDC max.
SWITCHING CURRENT:	500 mA max.
SWITCHING POWER:	28 W
SWITCHING TIME:	on-time: 3 msec
	off-time: 3 msec

CE Label



This device conforms to the directive 89/336/EEC
approximation of the laws of the Member States of the
Community relating to electromagnetic compatibility

Rear view GPSGEN1575/MP

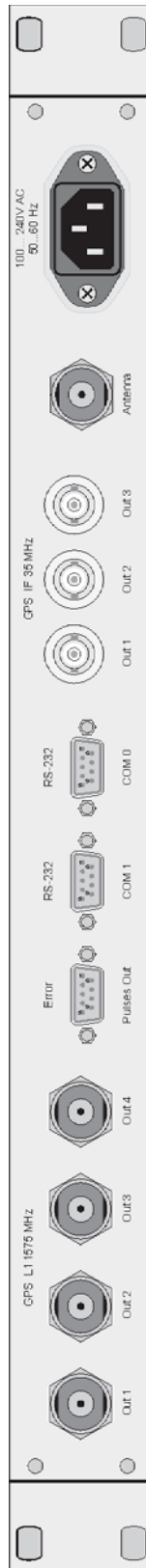

SUB-D assignment

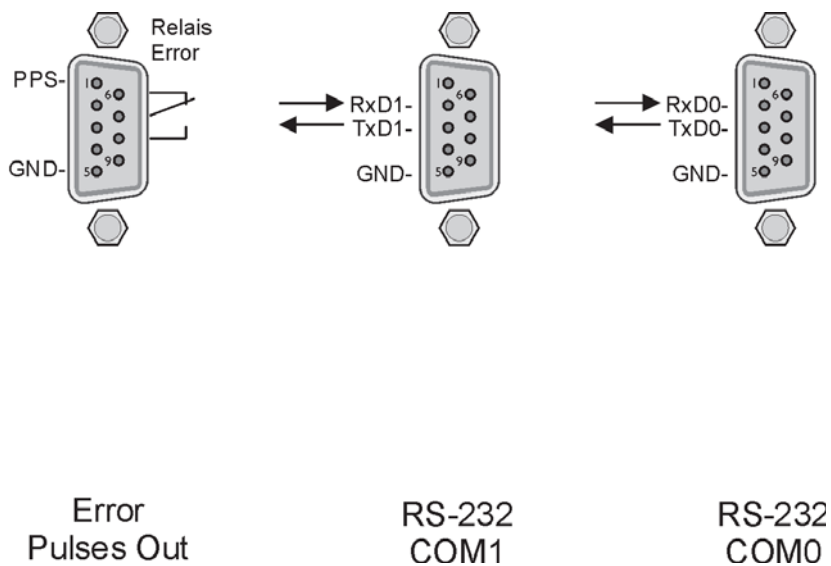

Connector assignments error relay (Time Sync)

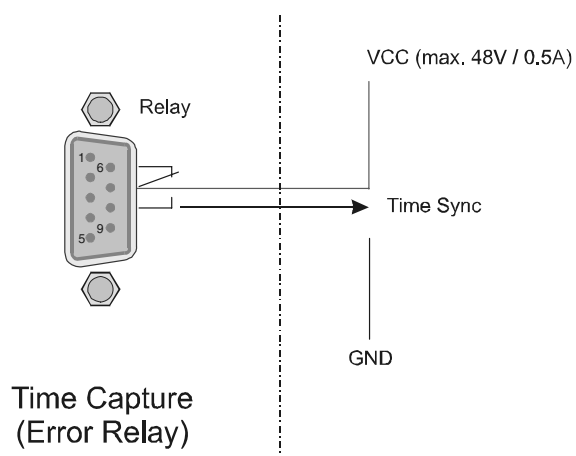

Relay on (pin. 7+8 are closed), if synchronization has been achieved

Relay off (pin. 6+7 are closed) after reset or in case of serious error

Technical specifications GPSGEN1575

RECEIVE FREQUENCY:	35.42 MHz	
MIXTURE FREQUENCY:	10 MHz	
OUTPUT FREQUENCY:	1575.42 MHz (GPS L1 C/A-code), distributed to four outputs	
OUTPUT IMPEDANCE:	50 Ω	
RECEIVER:	6 channel C/A code receiver with external antenna/converter unit	
ANTENNA:	Antenna/converter unit with remote power supply refer to chapter "Technical Specifications GPS Antenna"	
ANTENNA INPUT:	antenna circuit dc-insulated; dielectric strength: 1000V _{DC} Length of cable: refer to chapter "Mounting the Antenna"	
TIME TO SYNCHRO- NIZATION:	one minute with known receiver position and valid almanac 12 minutes if invalid battery buffered memory	
PULSE OUTPUT:	change of second (PPS, TTL level, pulse duration 1 msec) accuracy better than ± 250 nsec after synchronization and 20 minutes of operation better than ± 2 μ sec during the first 20 minutes of operation	
ACCURACY OF OSCILLATOR:	one day, free-running	$\pm 1 \cdot 10^{-7}$
	one year, free-running	$\pm 1 \cdot 10^{-6}$
TEMPERATURE DRIFT:	free running	$\pm 1 \cdot 10^{-6}$ (-20...70°C)
TIME_SYN OUTPUT:	TTL HIGH level if synchronized	

SERIAL PORTS: 2 asynchronous serial ports (RS-232)

Baud Rate: 300 up to 19200

Framing: 7N2, 7E1, 7E2, 8N1, 8N2, 8E1

default setting: COM0: 19200, 8N1

COM1: 9600, 8N1

POWER

REQUIREMENTS: $5V \pm 5\%$ / @ 550 mA

PHYSICAL

DIMENSION: Eurocard, 100 mm x 160 mm, 1.5 mm Epoxy

REAR EDGE

CONNECTOR: according to DIN 41612, type C 64, rows a+c (male)

AMBIENT

TEMPERATURE: 0 ... 50°C

HUMIDITY: 85% max.

Format of the Meinberg Standard Time String

The Meinberg Standard Time String is a sequence of 32 ASCII characters starting with the STX (start-of-text) character and ending with the ETX (end-of-text) character. The format is:

<STX>D:*dd.mm.yy*;T:*w*;U:*hh.mm.ss*;uvxy<ETX>

The letters printed in *italics* are replaced by ASCII numbers whereas the other characters are part of the time string. The groups of characters as defined below:

<STX> Start-Of-Text (ASCII code 02h)

dd.mm.yy the current date:

dd day of month (01..31)

mm month (01..12)

yy year of the century (00..99)

w the day of the week (1..7, 1 = Monday)

hh.mm.ss the current time:

hh hours (00..23)

mm minutes (00..59)

ss seconds (00..59, or 60 while leap second)

uv clock status characters:

u: ‘#’ clock has not synchronized after reset

‘ ‘ (space, 20h) clock has synchronized after reset

v: different for DCF77 or GPS receivers:

‘*’ DCF77 clock currently runs on XTAL

GPS receiver has not checked its position

‘ ‘ (space, 20h) DCF77 clock is sync'd with transmitter

GPS receiver has determined its position

x time zone indicator:

‘U’ UTC Universal Time Coordinated, formerly GMT

‘ ‘ MEZ European Standard Time, daylight saving disabled

‘S’ MESZ European Summertime, daylight saving enabled

y announcement of discontinuity of time, enabled during last hour before discontinuity comes in effect:

‘!’ announcement of start or end of daylight saving time

‘A’ announcement of leap second insertion

‘ ‘ (space, 20h) nothing announced

<ETX> End-Of-Text (ASCII code 03h)

Format of the SAT-Time String

The SAT-Time String is a sequence of 29 ASCII characters starting with the STX (start-of-text) character and ending with the ETX (end-of-text) character. The format is:

<STX>*dd.mm.yy/w/hh:mm:ssxxxuv***<ETX>**

The letters printed in *italics* are replaced by ASCII numbers whereas the other characters are part of the time string. The groups of characters as defined below:

<STX> Start-Of-Text (ASCII code 02h)

dd.mm.yy the current date:

dd day of month (01..31)

mm month (01..12)

yy year of the century (00..99)

w the day of the week (1..7, 1 = Monday)

hh:mm:ss the current time:

hh hours (00..23)

mm minutes (00..59)

ss seconds (00..59, or 60 while leap second)

xxxx time zone indicator:

‘UTC’ Universal Time Coordinated, formerly GMT

‘MEZ’ European Standard Time, daylight saving disabled

‘MESZ’ European Summertime, daylight saving enabled

u clock status characters:

‘#’ clock has not synchronized after reset

‘ ‘ (space, 20h) clock has synchronized after reset

v announcement of discontinuity of time, enabled during last hour before discontinuity comes in effect:

‘!’ announcement of start or end of daylight saving time

‘ ‘ (space, 20h) nothing announced

<CR> Carriage-return (ASCII code 0Dh)

<LF> Line-feed (ASCII code 0Ah)

<ETX> End-Of-Text (ASCII code 03h)

Format of the Uni Erlangen String (NTP)

The time string Uni Erlangen (NTP) of a **GPS-clock** is a sequence of 68 ASCII characters starting with the STX (start-of-text) character and ending with the ETX (end-of-text) character. The format is:

<STX>tt.mm.jj; w; hh:mm:ss; voo:oo; acdfg i;bbb.bbbbn ll.lllle hhhhm<ETX>

The letters printed in *italics* are replaced by ASCII numbers whereas the other characters are part of the time string. The groups of characters as defined below:

<i><STX></i>	Start-Of-Text (ASCII code 02h)
<i>dd.mm.yy</i>	the current date: <i>dd</i> day of month (01..31) <i>mm</i> month (01..12) <i>yy</i> year of the century (00..99)
<i>w</i>	the day of the week (1..7, 1 = Monday)
<i>hh.mm.ss</i>	the current time: <i>hh</i> hours (00..23) <i>mm</i> minutes (00..59) <i>ss</i> seconds (00..59, or 60 while leap second)
<i>v</i>	sign of the offset of local timezone related to UTC
<i>oo:oo</i>	offset of local timezone related to UTC in hours and minutes
<i>ac</i>	clock status characters: <i>a</i> : ‘#’ clock has not synchronized after reset ‘ ‘ (space, 20h) clock has synchronized after reset <i>c</i> : ‘*’ GPS receiver has not checked its position ‘ ‘ (space, 20h) GPS receiver has determined its position
<i>d</i>	time zone indicator: ‘S’ MESZ European Summertime, daylight saving enabled ‘ ‘ MEZ European Standard Time, daylight saving disabled
<i>f</i>	announcement of discontinuity of time, enabled during last hour before discontinuity comes in effect: ‘!’ announcement of start or end of daylight saving time ‘ ‘ (space, 20h) nothing announced
<i>g</i>	announcement of discontinuity of time, enabled during last hour before discontinuity comes in effect: ‘A’ announcement of leap second insertion ‘ ‘ (space, 20h) nothing announced

i leap second insertion
 'L' leap second is actually inserted
 (active only in 60th sec.)
 ' ' (space, 20h) no leap second is inserted

bbb.bbbb latitude of receiver position in degrees
 leading signs are replaced by a space character (20h)

n latitude, the following characters are possible:
 'N' north of equator
 'S' south d. equator

lll.lll longitude of receiver position in degrees
 leading signs are replaced by a space character (20h)

e longitude, the following characters are possible:
 'E' east of Greenwich
 'W' west of Greenwich

hhh altitude above sea level in meters
 leading signs are replaced by a space character (20h)

<ETX> End-Of-Text (ASCII-Code 03h)

Format of the ABB SPA Time String

The ABB SPA Time String is a sequence of 32 ASCII characters starting with the characters ">900WD" and ending with the <CR> (Carriage Return) character. The format is:

>900WD;*yy-mm-tt_hh.mm;ss.fff*:*cc***<CR>**

The letters printed in *italics* are replaced by ASCII numbers whereas the other characters are part of the time string. The groups of characters as defined below:

<i>yy-mm-tt</i>	the current date:	
<i>yy</i>	year of the century	(00..99)
<i>mm</i>	month	(01..12)
<i>dd</i>	day of month	(01..31)
–	Space (ASCII code 20h)	
<i>hh.mm;ss.fff</i>	the current time:	
<i>hh</i>	hours	(00..23)
<i>mm</i>	minutes	(00..59)
<i>ss</i>	seconds	(00..59, or 60 while leap second)
<i>fff</i>	milliseconds	(000..999)
<i>cc</i>	Check sum. EXCLUSIVE-OR result of the previous characters, displayed as a HEX byte (2 ASCII characters 0..9 or A..F)	
<CR>	Carriage Return (ASCII code 0Dh)	

Signal description GPSGEN1575

Name	Pin	Function
GND	32a+c	Ground
VCC in (+5V)	1a+c	+5V supply
VDD in (+5V Osc)	1a+c	+5V supply for oscillator (TCXO)
BSL1	4a	Pin1 of BSL key
BSL2 (+3,3V)	4a	Pin2 of BSL key
10 MHz out	12a	10 MHz frequency output, TTL-level
P_SEC out	6c	Pulse when second changes, TTL level, active high, length 1 msec
DCF_MARK out	17c	DCF77 compatible second marks, TTL level active high, length 100/200 msec
TIME_SYN out	19c	TTL output, HIGH level if synchronization has been achieved, LOW level after reset or in case of serious errors (e.g. antenna faulty)
COMx TxD out	26c,24c	COMx RS-232 transmit data output
COMx RxD in	30c,29c	COMx RS-232 receive data input

Rear connector pin assignments GPSGEN1575

	a	c
1	VCC in (+5V)	VCC in (+5V)
2		
3	VDD in (+5V Osc)	VDD in (+5V Osc)
4	BSL1	
5	BSL2 (+3.3V)	
6		P_SEC out
7		
8		
9		
10		
11		
12	10 MHz out	
13		
14		
15		
16		
17		DCF_MARK out
18		
19		TIME_SYN out
20		
21		
22		
23		
24		COM1 TxD out
25		
26		COM0 TxD out
27		
28		
29		COM1 RxD in
30		COM0 RxD in
31		GND
32	GND	GND

male connector according to DIN 41612, type C 64, rows a + c

Technical specifications power supply (T-60B)

INPUT: 85 ... 264V AC, 47 ... 63Hz, 1A/230V, 2A/115V

FUSE: elektronik

CURRENT
LIMITING:

105 - 150% $I_{out\ nom}$

OUTPUTS:

V_{out1} : 5.05V / 5A
 V_{out2} : +12V / 2.5A
 V_{out3} : -12V / 0.5A

TOTAL

LOAD: max. 61Watt

CONNECTORS: screw terminal

HOUSING: metal housing : 159mm x 97mm x 38mm

AMBIENT

TEMPERATURE: -10°C ... +60°C

HUMIDITY: 90% max.

Technical specifications of optional GPS antenna

ANTENNA: dielectrical patch antenna, 25 x 25mm
receive frequency: 1575.42 MHz
bandwidth: 9 MHz

CONVERTER: local oscillator to converter frequency: 10 MHz
first IF frequency: 35.4 MHz

POWER

REQUIREMENTS: 12V ... 18V, @ 100mA (provided via antenna cable)

CONNECTOR: coax type N, female

AMBIENT

TEMPERATURE: -40 ... +65°C

HOUSING: ABS plastic case for outdoor installation (IP56)

PHYSICAL

DIMENSION:

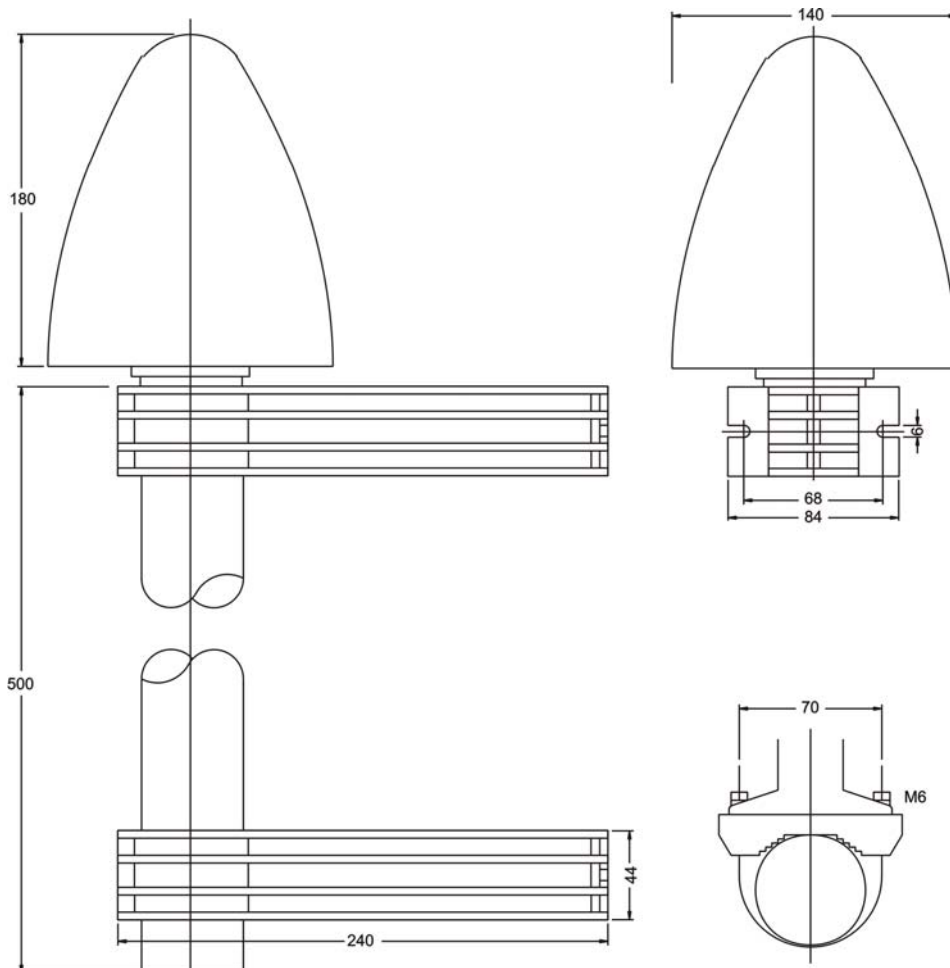

The program GPSMON32

The program GPSMON32 can be used to monitor and program all essential functions of Meinberg GPS-Receivers. The Software is executable under Win9x, Win2000, WinXP and WinNT. To install GPSMON32 just run Setup.exe from the included diskette and follow the instructions of the setup program.

Program and clock can communicate either via serial link or via TCP/IP connection if the clock is prepared for (LANXPT or SCU-XPT board). The mode to be used can be selected in menu ,Connection->Settings' by the checkboxes serial and network.

Serial Connection

To obtain a connection between your PC and the GPS-receiver, connect the receivers COM0 port to a free serial port of your PC. The PC's comport used by the program GPSMON32 can be selected in submenu '**PC-Comport**' in menu '**Connection**'.

Also transfer rate and framing used by the program are selected in this menu. Communication between the clock and the PC comes about, only if the GPS serial port is configured in the same way as the PC's comport. You can enforce an access, if the GPS serial port is not configured with appropriate parameters for communication. Select the menu item '**Enforce Connection**' in menu '**Connection**' and click '**Start**' in the appearing window. Some firmware versions of GPS170SV do not support this way of setting up a connection. If '**Enforce Connection**' doesn't succeed apparently, please change the serial port parameter of GPS COM0 manually to the PC's parameters.

Network Connection

Settings needed for a network connection can be done in menu ,Connection->Settings'.

To set up a network connection from clock to program GPSMON32, the mode ,network' must be selected in field ,mode'. Further the TCP/IP-Address must be entered in field ,IP-Address'. If the IP-Address is unknown, user can let the program search for available clocks in the local network by clicking the ,Find' button. A new connection can be set up by clicking to one of the displayed addresses. Access to radioclocks by network is always protected by a Password.

The online Help function of GPSMON32 provides detailed information on setting up a TCP/IP connection.

Online Help

The online help can be started by clicking the menu item 'Help' in menu Help. In every program window a direct access to a related help topic can be obtained by pressing F1. The help language can be selected by clicking the menu items Deutsch/English in the Help Menu.

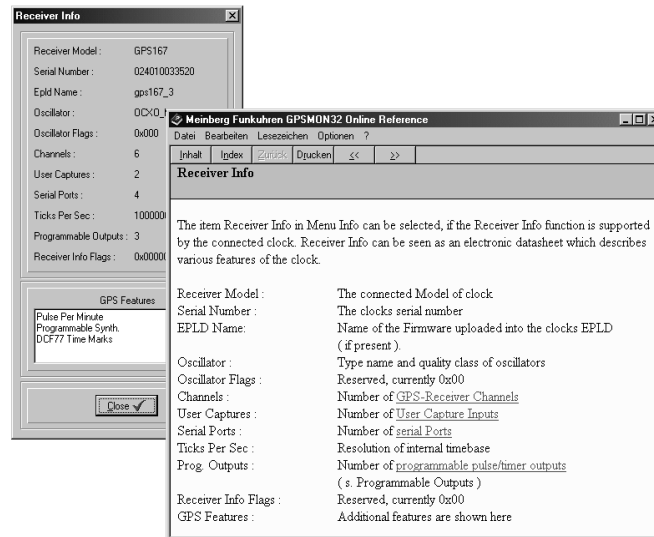

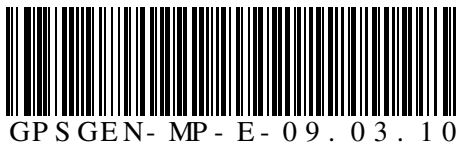

GPS GEN- MP- E- 09. 03. 10